

SCHMID-M

...since 1989

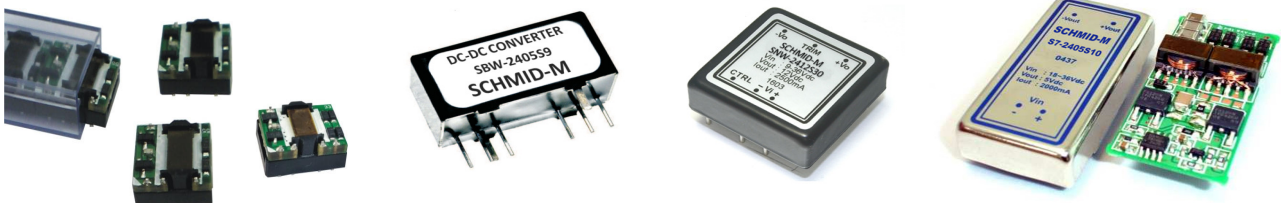

DC-DC Converter & AC-DC Converter PRODUCT Catalog



Product Overview



DC/DC Converter

page	Model Number	Watt	Case
3	SB XT-W2R2	0,25 Watt	SMD
4	SB XT-1WR3	1 Watt	SMD
5	T1-1W	1 Watt	SMD
6	SURB MT-3WR3	3 Watt	SMD
7	SA -1W	1 Watt	SIL4 & DIL8
8	S1 -1W	1 Watt	SIL7 & DIL14
9	SMB-1W	1 Watt	SIL6
10	SB-3W	3 Watt	SIL8
11	SBW-3W	3 Watt	SIL9
12	SB-6W	6 Watt	SIL8
13	SBW-6W	6 Watt	SIL8
14	SB-9W	9 Watt	SIL8
15	SBW-9W	9 Watt	SIL8
16	SD-10W	10 Watt	DIL24
17	SV-10W	10 Watt	DIL24
18	SN-15W	15 Watt	1x1
19	SNW-15W	15 Watt	1x1
20	ST-30W	30 Watt	2x1
21	STW-30W	30 Watt	2x1
22	ST-40W	40 Watt	2x1
23	SM40A	40 Watt	2x2
24	STW-50W	50 Watt	2x1
25	STW-60W	60 Watt	2x1
26	SURF24_QB-100W	100 Watt	61,8x40,x27,7
27	SURF48_QB-200W	200 Watt	61,8x40,x27,7
28	SLD300T	300 Watt	Full Brick
29	SLD400T	400 Watt	Full Brick

Non Isolated DC/DC Converter

page	Model Number	Watt	Case
30	SK78T-500R3	0,5A	SMD
31	SK78T-1000R3	1A	SMD
32	SK78-500R3	0,5A	SIP3
33	S01D-1A	1A	SIP3
34	S01D-2A	2A	SIP3
35	S01D-3A	3A	open frame

AC/DC Converter

page	Model Number	Watt	Case
36	SLS01	1W	open frame
37	SLS05	5W	open frame
38	SLD10	10W	DIP,chassis,DIN-RAIL
39	SLD20	20W	DIP,chassis,DIN-RAIL
40	SLH40	40W	DIP,chassis,DIN-RAIL
41	SLH60	60W	DIP,chassis,DIN-RAIL
42	SALR100	100W	127x88,9x17,2mm
43	SALR150	150W	127x88,9x17,2mm

SB_XT-W2R2 DC/DC Converter



FEATURES

- Continuous short-circuit protection
- Operating temperature range: -40°C to +105°C
- High efficiency up to 79%
- Miniature SMD package
- Isolation: 1.5kVDC, 3kV available
- Ultra-Low ripple & noise
- International standard pin-out

MODEL SELECTION GUIDE

also available in dual output

Part No.	Input Voltage (VDC)	Output		Efficiency (%Min./Typ.) @ Full Load	Max. Capacitive Load (μ F)
	Nominal (Range)	Output Voltage (VDC)	Output Current (mA)(Max./Min.)		
SB0305XT-W2R2	3.3 (2.97-3.63)	5	50/5	69/74	220
SB0503XT-W2R2	5 (4.5-5.5)	3.3	76/8	69/74	
SB0505XT-W2R2		5	50/5	72/77	
SB1205XT-W2R2	12 (10.8-13.2)	5	50/5	70/75	
SB1209XT-W2R2		9	28/3	74/79	
SB1212XT-W2R2		12	21/2	72/77	
SB2405XT-W2R2	24 (21.6-26.4)	5	50/5	64/69	

MECHANICAL SPECIFICATIONS

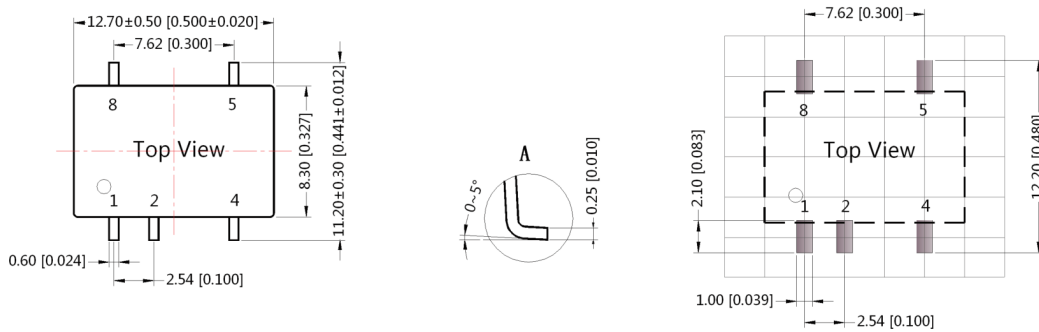

Note: Grid 2.54*2.54mm

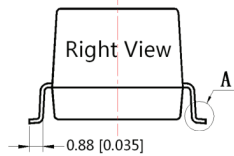
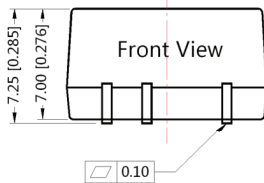

Note:
Unit: mm[inch]
General tolerances: 0.25[0.010]

Pin-Out	
Pin	Function
1	GND
2	Vin
4	0V
5	+Vo
8	NC

SB_XT-1WR3 DC/DC Converter

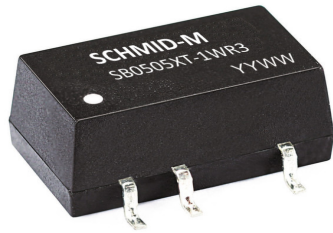

FEATURES

- Isolation: 1.5kV, 3kV available
- Operating temperature: -40°C to +105°C
- Miniature SMD package
- Internal surface mounted design
- No external component required
- International standard pin-out

MODEL SELECTION GUIDE *also available in dual output*

Part No.	Input Voltage (VDC)	Output		Efficiency (% Min./Typ.) @ Full Load	Max. Capacitive Load (µF)
	Nominal (Range)	Output Voltage (VDC)	Output Current (mA) (Max./Min.)		
SB0303XT-1WR2	3.3 (2.97-3.63)	3.3	303/30	68/72	220
SB0305XT-1WR2		5	200/20	70/74	
SB0312XT-1WR2		12	84/9	76/80	
SB0324XT-1WR2		24	42/4	76/80	
SB0503XT-1WR2	5 (4.5-5.5)	3.3	303/30	70/74	
SB0505XT-1WR2		5	200/20	76/80	
SB0509XT-1WR2		9	111/12	76/80	
SB0512XT-1WR2		12	84/9	76/80	
SB0524XT-1WR2		24	42/4	76/80	
SB1203XT-1WR2	12 (10.8-13.2)	3.3	303/30	70/74	
SB1205XT-1WR2		5	200/20	76/80	
SB1209XT-1WR2		9	111/12	76/80	
SB1212XT-1WR2		12	84/9	77/81	
SB1215XT-1WR2		15	67/7	77/81	
SB2405XT-1WR2	24 (21.6-26.4)	5	200/20	76/80	
SB2409XT-1WR2		9	111/12	76/80	
SB2412XT-1WR2		12	84/9	76/80	
SB2424XT-1WR2		24	42/4	77/81	

MECHANICAL SPECIFICATIONS

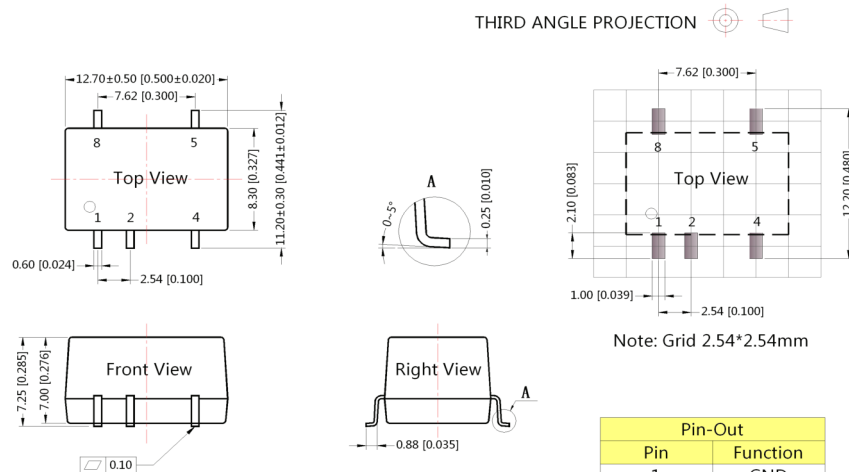

Note:
 Unit: mm[inch]
 Pin section tolerances: $\pm 0.10[\pm 0.004]$
 General tolerances: $\pm 0.25[\pm 0.010]$

Pin-Out	
Pin	Function
1	GND
2	Vin
4	0V
5	+Vo
8	NC

NC: No Connection

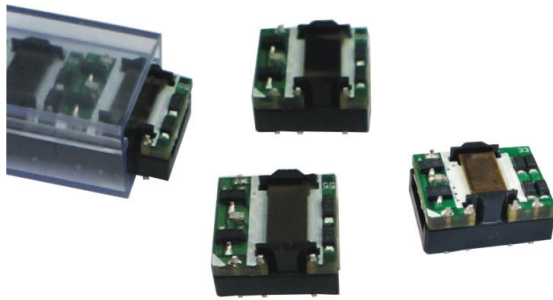

FEATURES

- SMD 8Pin / 10Pin Package
- 4200 VDC High Isolation
- Efficiency up to 78%
- -40 ~ 105°C Operation Temperature Range
- Rated working voltage for 250Vrms and 400Vdc
- Low coupling capacity
- Qualified for Lead-free Reflow Solder Process
- According to IPC/JEDEC J-STD-020D.1
- Tape & Reel Package Available

MODEL SELECTION GUIDE

MODEL NUMBER	INPUT Voltage Range (V dc)	INPUT Current		OUTPUT Voltage (V dc)	OUTPUT Current Full load (mA)	EFFICIENCY @FL (% , typ.)	Capacitor Load @FL (μF, max.)
		No-Load (mA, max.)	Full Load (mA, typ.)				
T1-0303SH	3.3 (2.97 ~ 3.63)	50	416	3.3	303	73	220
T1-0305SH	3.3 (2.97 ~ 3.63)	50	404	5	200	75	220
T1-0503SH	5 (4.5 ~ 5.5)	40	274	3.3	303	73	220
T1-0505SH	5 (4.5 ~ 5.5)	40	264	5	200	76	220
T1-0303SH-R	3.3 (2.97 ~ 3.63)	50	416	3.3	303	73	220
T1-0305SH-R	3.3 (2.97 ~ 3.63)	50	404	5	200	75	220
T1-0503SH-R	5 (4.5 ~ 5.5)	40	274	3.3	303	73	220
T1-0505SH-R	5 (4.5 ~ 5.5)	40	264	5	200	76	220
T1-0303DH	3.3 (2.97 ~ 3.63)	50	404	±3.3	±151	75	±100
T1-0305DH	3.3 (2.97 ~ 3.63)	50	389	±5	±100	78	±100
T1-0503DH	5 (4.5 ~ 5.5)	40	267	±3.3	±151	75	±100
T1-0505DH	5 (4.5 ~ 5.5)	40	257	±5	±100	78	±100
T1-0303DH-R	3.3 (2.97 ~ 3.63)	50	404	±3.3	±151	75	±100
T1-0305DH-R	3.3 (2.97 ~ 3.63)	50	389	±5	±100	78	±100
T1-0503DH-R	5 (4.5 ~ 5.5)	40	267	±3.3	±151	75	±100
T1-0505DH-R	5 (4.5 ~ 5.5)	40	257	±5	±100	78	±100

MECHANICAL SPECIFICATIONS

SMD 8Pin Package

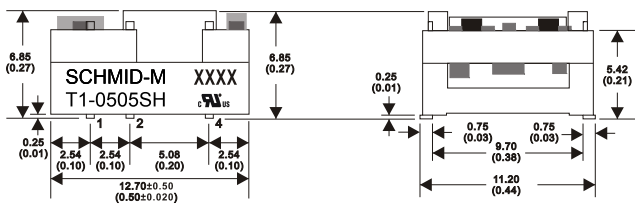

PIN CONNECTIONS		
PIN NUMBER	SINGLE	
1	- V Input	
2	+V Input	
4	- V Output	
5	+V Output	
8	N.C	

SMD 10Pin Package

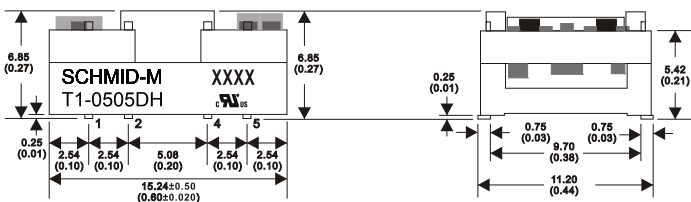

PIN CONNECTIONS		
PIN NUMBER	DUAL	
1	-V Input	
2	+V Input	
4	Common	
5	- V Output	
7	+V Output	
10	N.C	

SURB_MT-3WR3 DC/DC Converter



FEATURES

- Ultra wide input voltage rang (4:1)
- High efficiency up to 84%
- No-load power consumption as low as 0.10W
- Isolation voltage: 1.5K VDC
- Input Under-voltage Protection, output short-circuit protection , over-current protection
- Operating temperature range: -40°C to +85°C
- International standard pin-out
- IEC60950 , UL60950 , EN60950 approval

MODEL SELECTION GUIDE

Certification	Part No.	Input Voltage (VDC)		Output		Efficiency ² (%, Min./Typ.) @ Full Load	Max. Capacitive Load(μF)
		Nominal (Range)	Max. ¹	Output Voltage (VDC)	Output Current (mA) (Max./Min.)		
--	SURB2403MT-3WR3	24 (9-36)	40	3.3	728/0	73/75	2200
UL /CE/ CB	SURB2405MT-3WR3			5	600/0	78/80	2200
--	SURB2409MT-3WR3			9	333/0	78/80	1000
UL/ CE/ CB	SURB2412MT-3WR3			12	250/0	80/82	680
	SURB2415MT-3WR3			15	200/0	81/83	470
	SURB2424MT-3WR3			24	125/0	80/82	100
CE	SURB4803MT-3WR3	48 (18-75)	80	3.3	728/0	73/75	2200
	SURB4805MT-3WR3			5	600/0	77/79	2200
	SURB4812MT-3WR3			12	250/0	80/82	680
	SURB4815MT-3WR3			15	200/0	82/84	470
	SURB4824MT-3WR3			24	125/0	80/82	100

Notes:

- ① Exceeding the maximum input voltage may cause permanent damage;
- ② The efficiency value is measured in the input nominal voltage and output rated load.

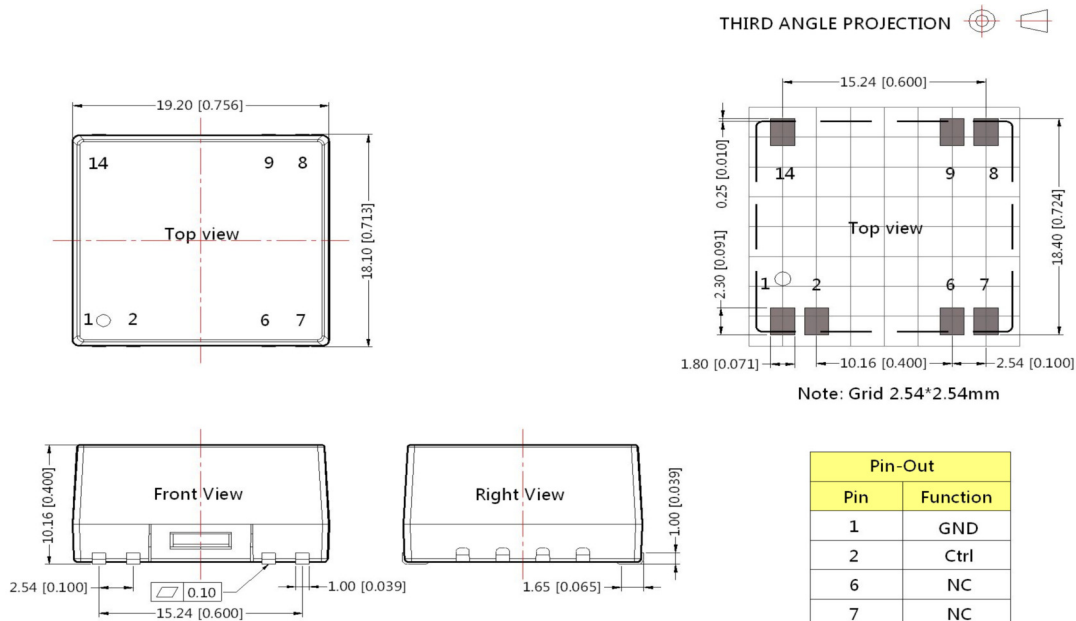

Note:
Unit: mm[inch]
Pin section tolerances: ±0.10[±0.004]
General tolerances: ±0.50[±0.020]

NC: No Connection

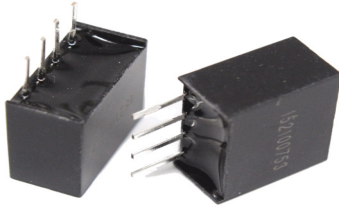

FEATURES

- 4 Pin SIL / 8 Pin DIL Package
- 1000 VDC Isolation
- Up to 3000 VDC Isolation
- Low Ripple and Noise
- Efficiency up to 83%
- -40 ~ 85°C Operation Temperature Range
- Non-Conductive Black Plastic Case
- EMI Complies With EN55022 Class B

MODEL SELECTION GUIDE

MODEL NUMBER	INPUT Voltage Range (Vdc)	INPUT Current		OUTPUT Voltage (Vdc)	OUTPUT Current		EFFICIENCY @FL(%)	Capacitor Load(μF)
		No-Load (mA)	Full Load (mA)		Full load (mA)			
SA-3R33R3S1	3.3	25	421	3.3	303	72	220	
SA-0505 S1	5	25	247	5	200	81	220	
SA-0509 S1	5	26	250	9	111	80	220	
SA-0512 S1	5	25	300	12	100	80	220	
SA-0515 S1	5	35	244	15	67	82	220	
SA-0524 S1	5	35	289	24	50	83	220	
SA-1205 S1	12	16	105	5	200	79	220	
SA-1209 S1	12	15	107	9	111	78	220	
SA-1212 S1	12	15	125	12	100	80	220	
SA-1215 S1	12	15	105	15	67	79	220	
SA-1218 S1	12	20	104	18	56	80	220	
SA-1224 S1	12	25	123	24	50	81	220	
SA-1505 S1	15	9	82	5	200	81	220	
SA-1509 S1	15	10	90	9	111	74	220	
SA-1512 S1	15	13	100	12	100	80	220	
SA-1515 S1	15	15	84	15	67	79	220	
SA-1524 S1	15	10	99	24	50	81	220	
SA-2405 S1	24	8	52	5	200	80	220	
SA-2409 S1	24	7	54	9	111	77	220	
SA-2412 S1	24	8	62	12	100	80	220	
SA-2415 S1	24	8	51	15	67	81	220	
SA-2424 S1	24	9	60	24	50	83	220	

MECHANICAL SPECIFICATIONS

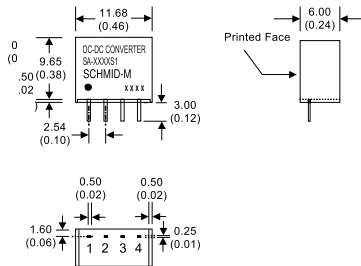

* The thickness of 48V input voltage model is 7.50(0.29)

4 Pin SIL Package

- Notes : All dimensions are typical in millimeters (inches).
1. Pin diameter: 0.5±0.05 (0.02±0.002)
 2. Pin pitch and length tolerance: ±0.35 (±0.014)
 3. Case Tolerance: ±0.5 (±0.02)

PIN CONNECTIONS	
PIN NUMBER	SINGLE
1	-V Input
2	+V Input
3	-V Output
4	+V Output

(The Pin Connection of high isolation one is the same with normal one.)

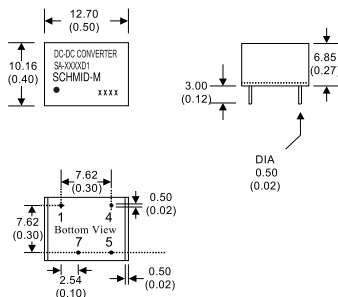

8 Pin DIL Package

- Notes : All dimensions are typical in millimeters (inches).
1. Pin diameter: 0.5±0.05 (0.02±0.002)
 2. Pin pitch and length tolerance: ±0.35 (±0.014)
 3. Case Tolerance: ±0.5 (±0.02)

PIN CONNECTIONS	
PIN NUMBER	SINGLE
1	-V Input
4	+V Input
5	+V Output
7	-V Output

(The Pin Connection of high isolation one is the same with normal one.)



FEATURES

- 7 Pin SIL / 14 Pin DIL Package
- 1000 VDC Isolation
- Up to 6000 VDC Isolation
- Low Ripple and Noise
- Efficiency up to 86%
- -40 ~ 85°C Operation Temperature Range
- Non-Conductive Black Plastic Case
- EMI Complies With EN55022 Class B

MODEL SELECTION GUIDE *also available in dual output*

MODEL NUMBER	INPUT Voltage Range (Vdc)	INPUT Current		OUTPUT Voltage (Vdc)	OUTPUT Current		EFFICIENCY @FL(%)	Capacitor Load(μF)
		No-Load (mA)	Full Load (mA)		Full load (mA)			
S1-0505SS	5	17	247	5	200	81	220	
S1-0509SS	5	15	244	9	111	82	220	
S1-0512SS	5	17	253	12	83	79	220	
S1-0515SS	5	17	233	15	67	86	220	
S1-2405SS	24	6	54	5	200	77	220	
S1-2412SS	24	6	53	12	83	78	220	
S1-2415SS	24	5	52	15	67	80	220	
S1-0512S	5	20	250	±12	±42	80	±100	
S1-0515S	5	20	244	±15	±33	82	±100	
S1-1515S	15	20	87	±15	±33	77	±100	
S1-2405S	24	6	56	±5.0	±100	74	±100	
S1-4805D	48	6	32	±5.0	±100	65	±100	
S1-4812D	48	6	29	±12	±42	71	±100	

MECHANICAL SPECIFICATIONS

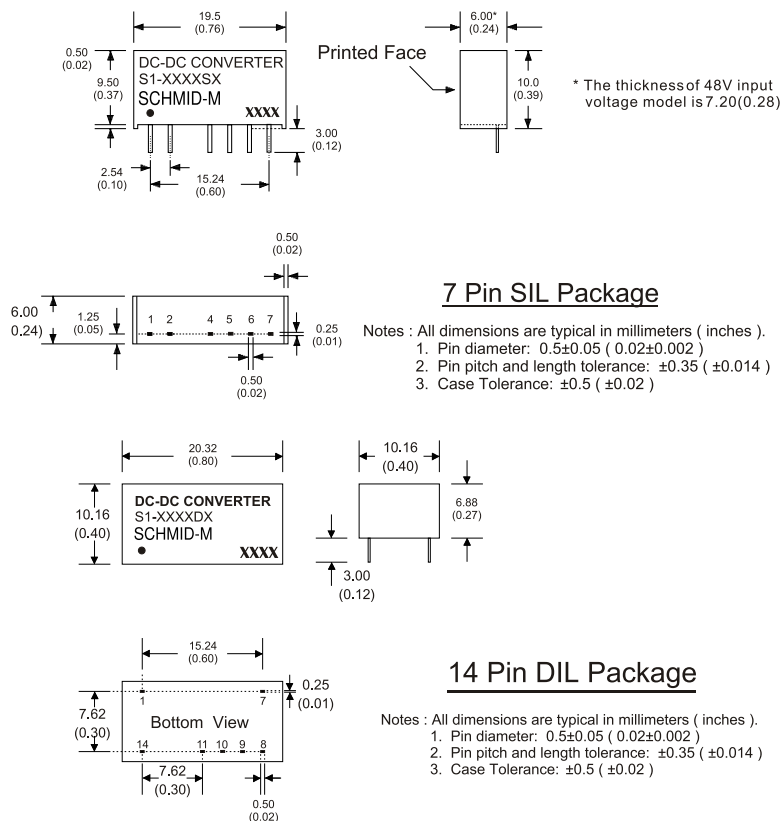

PIN CONNECTIONS				
PIN NUMBER	SINGLE	DUAL	SINGLE-H	DUAL-H
1	+V Input	+V Input	+V Input	+V Input
2	-V Input	-V Input	-V Input	-V Input
4	-V Output	-V Output	N.P.	N.P.
5	N.P.	Common	-V Output	-V Output
6	+V Output	+V Output	N.P.	Common
7	N.P.	N.P.	+V Output	+V Output

PIN CONNECTIONS				
PIN NUMBER	SINGLE	DUAL	SINGLE-H	DUAL-H
1	-V Input	-V Input	-V Input	-V Input
7	N.C.	N.C.	N.C.	N.C.
8	N.P.	Common	+V Output	+V Output
9	+V Output	+V Output	N.P.	Common
10	N.P.	N.P.	-V Output	-V Output
11	-V Output	-V Output	N.P.	N.P.
14	+V Input	+V Input	+V Input	+V Input



FEATURES

- 6 Pins SIL Package, Full SMD Technology Inside.
- Wide 2:1 Input Range
- 1500VDC Isolation
- Fully regulated output
- No minimum load required
- Continuous Short Circuit Protection
- Efficiency up to 81%
- Low Ripple and Noise
- 40°C ~ +85°C Operating Temperature Range

MODEL SELECTION GUIDE

also available in dual output

MODEL NUMBER	INPUT Voltage Range (Vdc)	INPUT Current		OUTPUT Voltage (Vdc)	OUTPUT Current		EFFICIENCY @FL (%)	Capacitive Load (uF)
		No-Load (mA)	Full Load (mA)		Min. load (mA)	Full load (mA)		
SMB-0505S1	4.5-9	35	263	5	0	200	76	1680
SMB-0512S1	4.5-9	35	253	12	0	83	79	820
SMB-0515S1	4.5-9	35	250	15	0	67	80	680
SMB-0524S1	4.5-9	35	250	24	0	42	80	470
SMB-1205S1	9-18	20	107	5	0	200	78	1680
SMB-1212S1	9-18	20	105	12	0	83	80	820
SMB-1215S1	9-18	20	103	15	0	67	81	680
SMB-1224S1	9-18	20	105	24	0	42	80	470
SMB-2405S1	18-36	10	54	5	0	200	78	1680
SMB-2412S1	18-36	10	52	12	0	83	80	820
SMB-2415S1	18-36	10	52	15	0	67	80	680
SMB-2424S1	18-36	10	52	24	0	42	81	470
SMB-4805S1	36-75	7	28	5	0	200	76	1680
SMB-4812S1	36-75	7	27	12	0	83	78	820
SMB-4815S1	36-75	7	27	15	0	67	78	680
SMB-4824S1	36-75	7	27	24	0	42	77	470

MECHANICAL SPECIFICATIONS

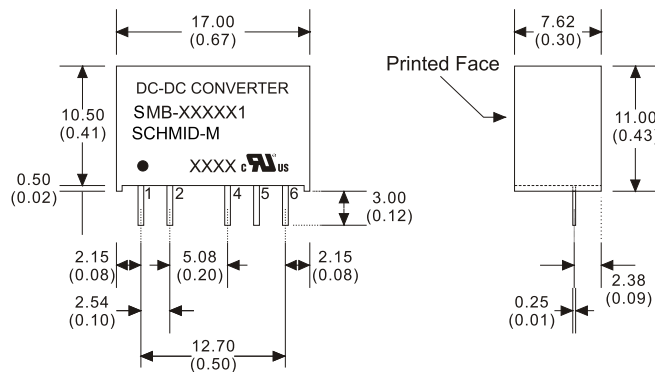

PIN CONNECTIONS		
PIN NUMBER	SINGLE	DUAL
1	-V Input	-V Input
2	+V Input	+V Input
4	+V Output	+V Output
5	N.P.	Common
6	-V Output	-V Output

6 Pin SIL Package

- Notes: All dimensions are typical in millimeters (inches).
1. Pin diameter: 0.5±0.05 (0.02±0.002)
 2. Pin pitch and length tolerance: ±0.35 (±0.014)
 3. Pin to case tolerance: ±0.5 (±0.02)
 4. Case Tolerance: ±0.5 (±0.02)
 5. Stand-off tolerance: ±0.1 (±0.004)

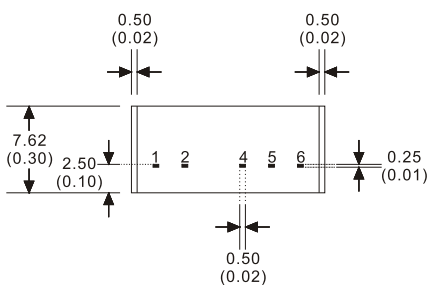



FEATURES

- 8 Pin SIL
- Wide 2:1 Input Range
- Full SMD Technology
- 1600 VDC Isolation
- Continuous Short Circuit Protection
- Efficiency up to 84%
- -40 ~ 71°C Operation Temperature Range
- Plastic Case Standard, Optional Metal Case
- Remote on/off Control (Optional)

MODEL SELECTION GUIDE

also available in dual output

MODEL NUMBER	INPUT Voltage Range (Vdc)	INPUT Current		OUTPUT Voltage (Vdc)	OUTPUT Current		EFFICIENCY @FL(%)	Capacitor Load(μF)
		No-Load (mA)	Full Load (mA)		Min. load (mA)	Full load (mA)		
SB-053R3S3C	4.5-9	65	640	3.3	175	700	74	2200
SB-0505S3C	4.5-9	70	800	5	150	600	76	1000
SB-0512S3C	4.5-9	75	750	12	62.5	250	82	470
SB-0515S3C	4.5-9	75	750	15	50	200	82	220
SB-123R3S3C	9-18	25	260	3.3	175	700	76	2200
SB-1205S3C	9-18	15	320	5	150	600	81	1000
SB-1212S3C	9-18	35	305	12	62.5	250	84	470
SB-1215S3C	9-18	35	305	15	50	200	84	220
SB-243R3S3C	18-36	15	133	3.3	175	700	74	2200
SB-2405S3C	18-36	15	160	5	150	600	79	1000
SB-2412S3C	18-36	20	156	12	62.5	250	82	470
SB-2415S3C	18-36	20	152	15	50	200	84	220
SB-483R3S3C	36-72	10	66	3.3	175	700	75	2200
SB-4805S3C	36-72	10	82	5	150	600	78	1000
SB-4812S3C	36-72	15	78	12	62.5	250	81	470
SB-4815S3C	36-72	15	78	15	50	200	81	220

MECHANICAL SPECIFICATIONS

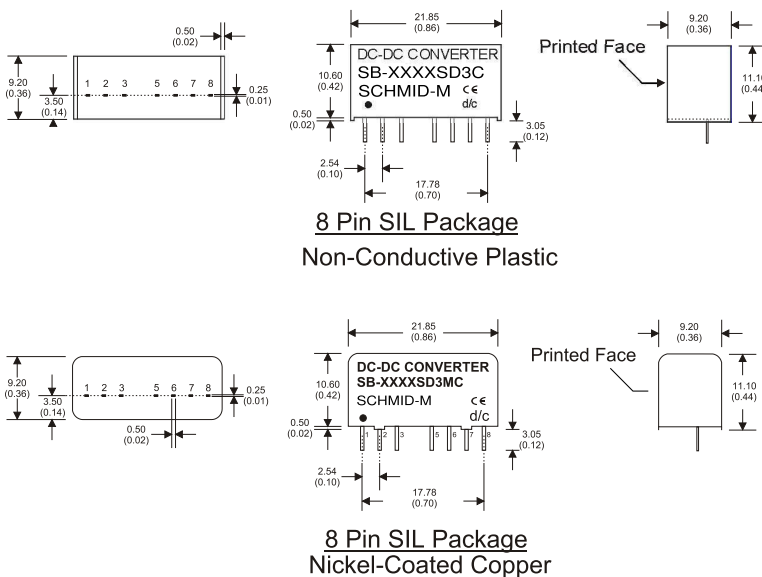

Notes : All dimensions are typical in millimeters (inches).
 1. Pin diameter: 1.0 ±0.05 (0.04 ±0.002)
 2. Pin pitch tolerance: ±0.35 (±0.014)
 3. Case Tolerance: ±0.5 (±0.02)

PIN CONNECTIONS

PIN NUMBER	SINGLE+C	DUAL+C
1	-V Input	-V Input
2	+V Input	+V Input
3	Remote On/Off	Remote On/Off
5	N.C.	N.C.
6	+V Output	+V Output
7	-V Output	Common
8	N.C.	-V Output

PIN CONNECTIONS

PIN NUMBER	SINGLE	DUAL
1	-V Input	-V Input
2	+V Input	+V Input
3	N.P.	N.C.
5	N.P.	N.C.
6	+V Output	+V Output
7	-V Output	Common
8	N.C.	-V Output



FEATURES

- 9 Pin SIL
- Wide 4:1 Input Range
- Full SMD Technology
- 1500 VDC Isolation
- Continuous Short Circuit Protection
- Efficiency up to 85%
- -40 ~ 75°C Operation Temperature Range
- Remote on/off Control

MODEL SELECTION GUIDE

also available in dual output

MODEL NUMBER	INPUT Voltage Range (Vdc)	INPUT Current		OUTPUT Voltage (Vdc)	OUTPUT Current		EFFICIENCY @FL (%)	Capacitor Load (uF)
		No-Load (mA)	Full Load (mA)		Min. load (mA)	Full load (mA)		
SBW-243R3S3	9-36	10	125	3.3	0	700	77	2200uF
SBW-2405S3	9-36	10	153	5	0	600	82	1000uF
SBW-2412S3	9-36	10	149	12	0	250	84	165uF
SBW-2415S3	9-36	10	148	15	0	200	85	100uF
SBW-483R3S3	18-75	5	65	3.3	0	700	75	2200uF
SBW-4805S3	18-75	5	78	5	0	600	81	1000uF
SBW-4812S3	18-75	5	75	12	0	250	84	165uF
SBW-4815S3	18-75	5	75	15	0	200	84	100uF
SBW-2405SD3	9-36	10	155	±5	0	±300	81	±470uF
SBW-2412SD3	9-36	10	149	±12	0	±125	84	±100uF
SBW-2415SD3	9-36	10	149	±15	0	±100	84	±47uF
SBW-4805SD3	18-75	5	78	±5	0	±300	81	±470uF
SBW-4812SD3	18-75	5	75	±12	0	±125	84	±100uF
SBW-4815SD3	18-75	5	76	±15	0	±100	83	±47uF

MECHANICAL SPECIFICATIONS

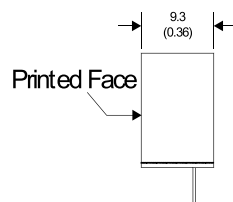
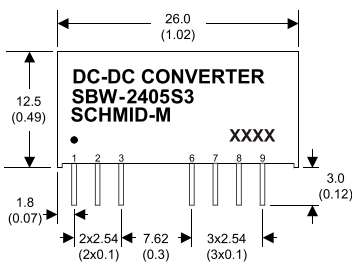

9 Pin SIL Package
Non-Conductive Plastic

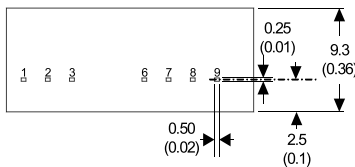

PIN CONNECTIONS		
PIN NUMBER	SINGLE	DUAL
1	-V Input	-V Input
2	+V Input	+V Input
3	Remote On/Off	Remote On/Off
6	+V Output	+V Output
7	N.C.	Common
8	N.C.	N.C.
9	-V Output	-V Output

Notes: All dimensions are typical in millimeters (inches).
 1. Pin diameter: 0.5 ±0.05 (0.02 ±0.002)
 2. Pin pitch and length tolerance: ±0.35 (±0.014)
 3. Case Tolerance: ±0.5 (±0.02)



FEATURES

- Highest Power Density In 8 Pin SIL Package
- Wide 2:1 Input Range
- Smallest Footprint 6W Converter
- No Minimum Load Required
- 1500 VDC Isolation , Up to 3000VDC
- Continuous Short Circuit Protection
- Efficiency up to 86%
- -40°C ~+ 65°C Operation Temperature Range
- Remote on/off Control (Optional)

MODEL SELECTION GUIDE

also available in dual output

MODEL NUMBER	INPUT Voltage Range (Vdc)	INPUT Current		OUTPUT Voltage (Vdc)	OUTPUT Current		EFFICIENCY @FL(%)	Capacitor Load(µF)
		No-Load (mA)	Full Load (mA)		Min. load (mA)	Full load (mA)		
SB -053R3S6	4.5-9	105	1114	3.3	0	1300	77	6600µF
SB -0505S6	4.5-9	105	1481	5	0	1200	81	3300µF
SB -0509S6	4.5-9	105	1445	9	0	666	83	2000µF
SB -0512S6	4.5-9	105	1428	12	0	500	84	1600µF
SB -0515S6	4.5-9	105	1428	15	0	400	84	1400µF
SB -0524S6	4.5-9	105	1428	24	0	250	84	680µF
SB -123R3S6	9-18	55	458	3.3	0	1300	78	6600µF
SB -1205S6	9-18	55	602	5	0	1200	83	3300µF
SB -1209S6	9-18	55	595	9	0	666	84	2000µF
SB -1212S6	9-18	55	588	12	0	500	85	1600µF
SB -1215S6	9-18	55	588	15	0	400	85	1400µF
SB -1224S6	9-18	55	595	24	0	250	84	680µF
SB -243R3S6	18-36	30	229	3.3	0	1300	78	6600µF
SB -2405S6	18-36	30	301	5	0	1200	83	3300µF
SB -2409S6	18-36	30	294	9	0	666	85	2000µF
SB -2412S6	18-36	30	294	12	0	500	85	1600µF
SB -2415S6	18-36	30	290	15	0	400	86	1400µF
SB -2424S6	18-36	30	294	24	0	250	85	680µF
SB -483R3S6	36-75	15	114	3.3	0	1300	78	6600µF
SB -4805S6	36-75	15	152	5	0	1200	82	3300µF
SB -4809S6	36-75	15	148	9	0	666	84	2000µF
SB -4812S6	36-75	15	147	12	0	500	85	1600µF
SB -4815S6	36-75	15	145	15	0	400	86	1400µF
SB -4824S6	36-75	15	148	24	0	250	84	680µF

MECHANICAL SPECIFICATIONS

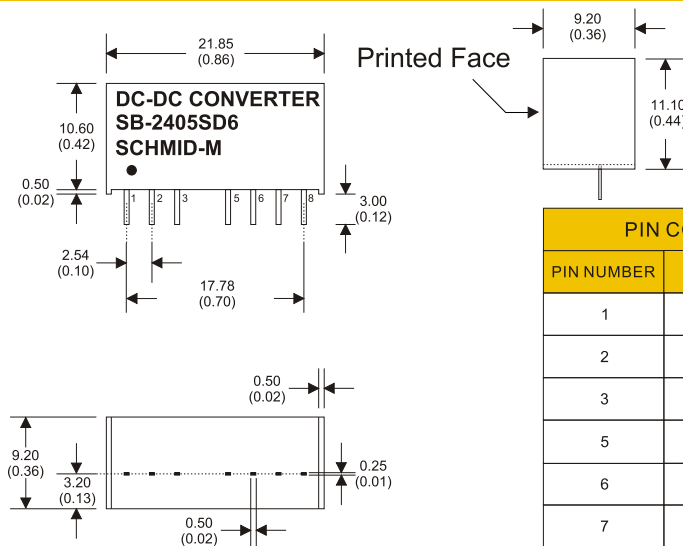

8 Pin SIL Package

- Notes : All dimensions are typical in millimeters (inches).
1. Pin diameter: 0.5±0.05 (0.02±0.002)
 2. Pin pitch and length tolerance: ±0.35 (±0.014)
 3. Pin to case tolerance: ±0.5 (±0.02)
 4. Case Tolerance: ±0.5 (±0.02)
 5. Stand-off tolerance: ±0.1 (±0.004)

PIN CONNECTIONS		
PIN NUMBER	SINGLE	DUAL
1	-V Input	-V Input
2	+V Input	+V Input
3	N.P.	N.C.
5	N.P.	N.C.
6	+V Output	+V Output
7	-V Output	Common
8	N.C.	-V Output

PIN CONNECTIONS		
PIN NUMBER	SINGLE + C	DUAL + C
1	-V Input	-V Input
2	+V Input	+V Input
3	Remote On/Off	Remote On/Off
5	N.C.	N.C.
6	+V Output	+V Output
7	-V Output	Common
8	N.C.	-V Output



FEATURES

- Highest Power Density In 8 Pin SIL Package
- Wide 4:1 Input Range
- Smallest Footprint 6W Converter
- No Minimum Load Required
- 500 VDC Isolation , Up to 3000VDC (Optional)
- Continuous Short Circuit Protection
- Efficiency up to 88%
- -40°C ~+ 71°C Operation Temperature Range
- Remote on/off Control

MODEL SELECTION GUIDE

also available in dual output

MODEL NUMBER	INPUT Voltage Range (Vdc)	INPUT Current		OUTPUT Voltage (Vdc)	OUTPUT Current		EFFICIENCY @FL(%)	Capacitor Load(uF)
		No-Load (mA)	Full Load (mA)		Min. load (mA)	Full load (mA)		
SBW-243R3S6	9-36	6	261	3.3	0	1500	79	4700uF
SBW-2405S6	9-36	6	298	5	0	1200	84	2200uF
SBW-2409S6	9-36	6	290	9	0	666	86	1000uF
SBW-2412S6	9-36	6	287	12	0	500	87	470uF
SBW-2415S6	9-36	6	287	15	0	400	87	220uF
SBW-2424S6	9-36	6	287	24	0	250	87	100uF
SBW-2405SD6	9-36	6	298	±5	0	±600	84	±330uF
SBW-2412SD6	9-36	6	291	±12	0	±250	86	±220uF
SBW-2415SD6	9-36	6	287	±15	0	±200	87	±100uF
SBW-483R3S6	18-75	6	131	3.3	0	1500	79	4700uF
SBW-4805S6	18-75	6	151	5	0	1200	83	2200uF
SBW-4809S6	18-75	6	147	9	0	666	85	1000uF
SBW-4812S6	18-75	6	144	12	0	500	87	470uF
SBW-4815S6	18-75	6	144	15	0	400	87	220uF
SBW-4824S6	18-75	6	144	24	0	250	87	100uF
SBW-4805SD6	18-75	6	152	±5	0	±600	82	±330uF
SBW-4812SD6	18-75	6	147	±12	0	±250	85	±220uF
SBW-4815SD6	18-75	6	145	±15	0	±200	86	±100uF

MECHANICAL SPECIFICATIONS

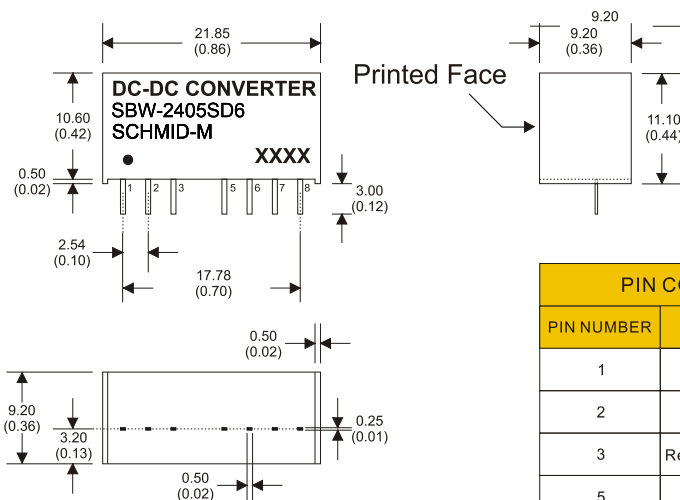

8 Pin SIL Package

- Notes : All dimensions are typical in millimeters (inches).
1. Pin diameter: 0.5±0.05 (0.02±0.002)
 2. Pin pitch and length tolerance: ±0.35 (±0.014)
 3. Pin to case tolerance: ±0.5 (±0.02)
 4. Case Tolerance: ±0.5 (±0.02)
 5. Stand-off tolerance: ±0.1 (±0.004)

PIN CONNECTIONS		
PIN NUMBER	SINGLE	DUAL
1	-V Input	-V Input
2	+V Input	+V Input
3	Remote On/Off	Remote On/Off
5	N.C.	N.C.
6	+V Output	+V Output
7	-V Output	Common
8	N.C	-V Output

PIN CONNECTIONS		
PIN NUMBER	SINGLE + C	DUAL + C
1	-V Input	-V Input
2	+V Input	+V Input
3	Remote On/Off	Remote On/Off
5	N.P.	N.P.
6	+V Output	+V Output
7	-V Output	Common
8	N.C	-V Output



FEATURES

- Highest Power Density In 8 Pin SIP Package
- Wide 2:1 Input Voltage Range
- Smallest Footprint 9W Converter
- -40°C ~+ 85°C Operation Temperature Range
- Efficiency Up To 90%
- Indefinite Short-Circuit Protection
- I/O Isolation 1600VDC
- Remote On/Off Control
- Fully RoHS Compliant

MODEL SELECTION GUIDE

also available in dual output

MODEL NUMBER	INPUT Voltage Range (Vdc)	INPUT Current		OUTPUT Voltage (Vdc)	OUTPUT Current		EFFICIENCY @FL (% , typ.)	Capacitor Load @FL (µF, max.)
		No-Load mA, max.)	Full Load (mA, typ.)		Min. load (mA)	Full load (mA)		
SB-123R3S9	9-18,12V Nom.	15	679	3.3	0	2000	81	2600
SB-1205S9	9-18,12V Nom.	15	784	5	0	1600	85	1300
SB-1209S9	9-18,12V Nom.	15	862	9	0	1000	87	800
SB-1212S9	9-18,12V Nom.	15	852	12	0	750	88	560
SB-1215S9	9-18,12V Nom.	15	843	15	0	600	89	470
SB-1224S9	9-18,12V Nom.	15	843	24	0	375	89	200
SB-243R3S9	18-36,24V Nom.	15	344	3.3	0	2000	80	2600
SB-2405S9	18-36,24V Nom.	15	392	5	0	1600	85	1300
SB-2409S9	18-36,24V Nom.	15	426	9	0	1000	88	800
SB-2412S9	18-36,24V Nom.	15	421	12	0	750	89	560
SB-2415S9	18-36,24V Nom.	15	417	15	0	600	90	470
SB-2424S9	18-36,24V Nom.	15	417	24	0	375	90	200
SB-483R3S9	36-75,48V Nom.	10	168	3.3	0	2000	82	2600
SB-4805S9	36-75,48V Nom.	10	196	5	0	1600	85	1300
SB-4809S9	36-75,48V Nom.	10	213	9	0	1000	88	800
SB-4812S9	36-75,48V Nom.	10	211	12	0	750	89	560
SB-4815S9	36-75,48V Nom.	10	211	15	0	600	89	470
SB-4824S9	36-75,48V Nom.	10	211	24	0	375	89	200

MECHANICAL SPECIFICATIONS

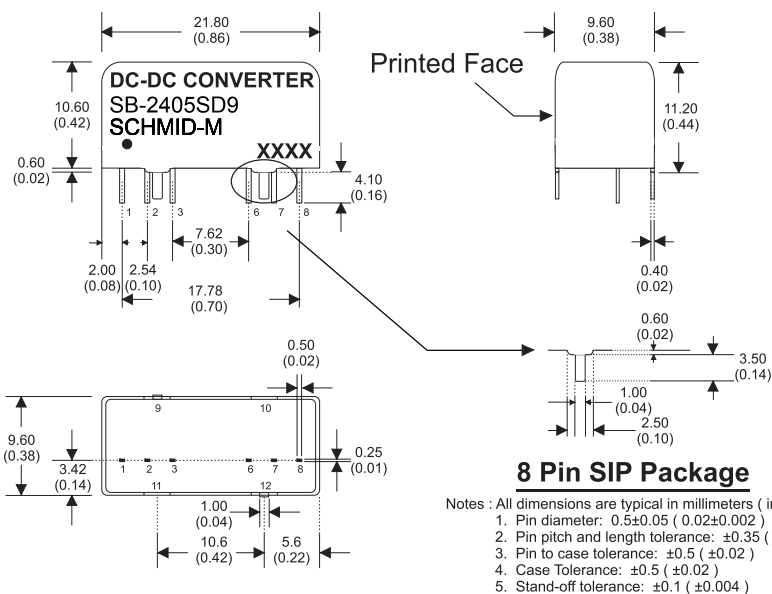

PIN CONNECTIONS		
PIN NUMBER	SINGLE	DUAL
1	-V Input	-V Input
2	+V Input	+V Input
3	Remote On/Off	Remote On/Off
6	+V Output	+V Output
7	-V Output	Common
8	N.C	-V Output
9	Case	Case
10	Stand Off	Stand Off
11	Stand Off	Stand Off
12	Case	Case



FEATURES

- Highest Power Density In 8 Pin SIP Package
- Wide 4:1 Input Voltage Range
- Smallest Footprint 9W Converter
- -40°C ~+ 85°C Operation Temperature Range
- Efficiency Up To 89%
- Indefinite Short-Circuit Protection
- I/O Isolation 1600VDC
- Remote On/Off Control
- Fully RoHS Compliant

MODEL SELECTION GUIDE

MODEL NUMBER	INPUT Voltage Range (Vdc)	INPUT Current		OUTPUT Voltage (Vdc)	OUTPUT Current		EFFICIENCY @FL (% , typ.)	Capacitor Load @FL (µF, max.)
		No-Load (mA, max.)	Full Load (mA, typ.)		Min. load (mA)	Full load (mA)		
SBW-243R3S9	9-36	9	335	3.3	0	2000	82	2600
SBW-2405S9	9-36	9	392	5	0	1600	85	1300
SBW-2409S9	9-36	9	426	9	0	1000	88	800
SBW-2412S9	9-36	9	426	12	0	750	88	560
SBW-2415S9	9-36	9	421	15	0	600	89	560
SBW-2424S9	9-36	9	421	24	0	375	89	200
SBW-2405SD9	9-36	9	392	±5	0	±800	85	±800
SBW-2412SD9	9-36	9	426	±12	0	±375	88	±390
SBW-2415SD9	9-36	9	431	±15	0	±300	87	±200
SBW-483R3S9	18-75	5	168	3.3	0	2000	82	2600
SBW-4805S9	18-75	5	196	5	0	1600	85	1300
SBW-4809S9	18-75	5	216	9	0	1000	87	800
SBW-4812S9	18-75	5	213	12	0	750	88	560
SBW-4815S9	18-75	5	211	15	0	600	89	560
SBW-4824S9	18-75	5	211	24	0	375	89	200
SBW-4805SD9	18-75	5	196	±5	0	±800	85	±800
SBW-4812SD9	18-75	5	216	±12	0	±375	87	±390
SBW-4815SD9	18-75	5	216	±15	0	±300	87	±200

MECHANICAL SPECIFICATIONS

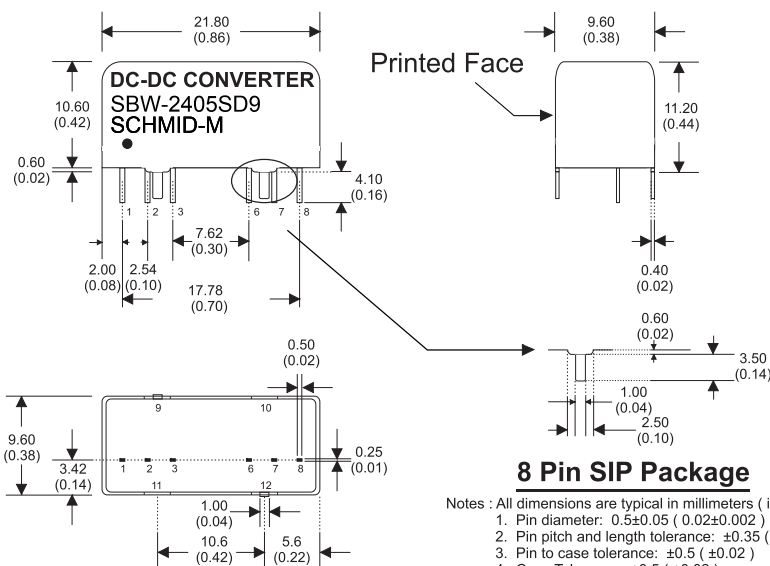

PIN CONNECTIONS		
PIN NUMBER	SINGLE	DUAL
1	-V Input	-V Input
2	+V Input	+V Input
3	Remote On/Off	Remote On/Off
6	+V Output	+V Output
7	-V Output	Common
8	N.C	-V Output
9	Case	Case
10	Stand Off	Stand Off
11	Stand Off	Stand Off
12	Case	Case

Notes : All dimensions are typical in millimeters (inches).
 1. Pin diameter: 0.5±0.05 (0.02±0.002)
 2. Pin pitch and length tolerance: ±0.35 (±0.014)
 3. Pin to case tolerance: ±0.5 (±0.02)
 4. Case Tolerance: ±0.5 (±0.02)
 5. Stand-off tolerance: ±0.1 (±0.004)



FEATURES

- Wide 2:1 Input Range
- Full SMD Technology
- 1500 VDC Isolation
- Efficiency up to 90%
- -40 ~ 85°C Operation Temperature Range
- Continuous Short Circuit Protection
- Over Voltage Protection
- Low no load Input Current
- Soft Start
- High Power Density: 10W in DIL-24 Package

MODEL SELECTION GUIDE

also available in dual output

MODEL NUMBER	INPUT Voltage Range (Vdc)	INPUT Current		OUTPUT Voltage (Vdc)	OUTPUT Current		EFFICIENCY @FL(%)	Capacitor Load(μF)
		No-Load (mA)	Full Load (mA)		Min. load (mA)	Full load (mA)		
SD-122R5S10	9-18	10	791	2.5	0	3000	81	2200
SD-123R3S10	9-18	10	1006	3.3	0	3000	84	2200
SD-1205S10	9-18	10	992	5	0	2000	86	2200
SD-1212S10	9-18	10	980	12	0	833	87	820
SD-1215S10	9-18	10	958	15	0	667	89	470
SD-1212D10	9-18	10	980	±12	0	±416	87	±220
SD-1215D10	9-18	10	969	±15	0	±333	88	±150
SD-242R5S10	18-36	10	381	2.5	0	3000	84	2200
SD-243R3S10	18-36	10	497	3.3	0	3000	85	2200
SD-2405S10	18-36	10	479	5	0	2000	89	2200
SD-2412S10	18-36	10	485	12	0	833	88	820
SD-2415S10	18-36	10	485	15	0	667	88	470
SD-2412D10	18-36	10	485	±12	0	±416	88	±220
SD-2415D10	18-36	10	474	±15	0	±333	90	±150
SD-482R5S10	36-75	10	191	2.5	0	3000	84	2200
SD-483R3S10	36-75	10	249	3.3	0	3000	85	2200
SD-4805S10	36-75	10	242	5	0	2000	88	2200

MECHANICAL SPECIFICATIONS

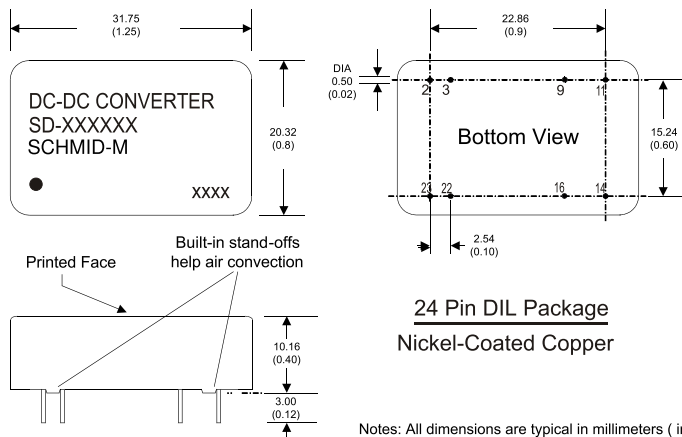

Notes: All dimensions are typical in millimeters (inches).
 1. Pin diameter: 0.5 ±0.05 (0.02 ±0.002)
 2. Pin pitch and length tolerance: ±0.35 (±0.014)
 3. Case Tolerance: ±0.5 (±0.02)

PIN CONNECTIONS

PIN NUMBER	SINGLE	DUAL
2	-V Input	-V Input
3	-V Input	-V Input
9	N.P.	Common
11	N.C.	-V Output
14	+V Output	+V Output
16	-V Output	Common
22	+V Input	+V Input
23	+V Input	+V Input

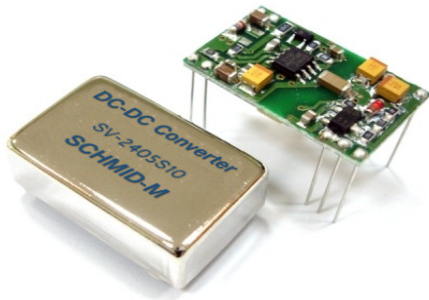

FEATURES

- Wide 4:1 Input Range
- Full SMD Technology
- 1600 VDC Isolation
- Efficiency up to 88%
- -40 ~ 85 °C Operation Temperature Range
- No Minimum Load Required
- Continuous Short Circuit Protection
- Over Voltage Protection
- Over Load Protection
- Low no load Input Current
- Soft Start
- High Power Density: 10W in DIL-24 Package
- Remote On/Off

MODEL SELECTION GUIDE

also available in dual output

MODEL NUMBER	INPUT Voltage Range (Vdc)	INPUT Current		OUTPUT Voltage (Vdc)	OUTPUT Current		EFFICIENCY @FL(%)	Capacitor Load(μF)
		No-Load (mA)	Full Load (mA)		Min. load (mA)	Full load (mA)		
SV-243R3S10	9-36	15	440	3.3	0	2700	85	1330
SV-2405S10	9-36	15	480	5	0	2000	87	1330
SV-2412S10	9-36	15	475	12	0	833	88	288
SV-2415S10	9-36	15	475	15	0	667	88	200
SV-2405D10	9-36	15	495	5	0	1000	85	900
SV-2412D10	9-36	15	480	12	0	417	87	133
SV-2415D10	9-36	15	480	15	0	330	87	90
SV-483R3S10	18-75	15	225	3.3	0	2700	84	1330
SV-4805S10	18-75	15	240	5	0	2000	87	1330
SV-4812S10	18-75	15	240	12	0	833	87	288
SV-4815S10	18-75	15	240	15	0	667	87	200
SV-4805D10	18-75	15	250	5	0	1000	85	900
SV-4812D10	18-75	15	240	12	0	417	88	133
SV-4815D10	18-75	15	240	15	0	330	88	90

MECHANICAL SPECIFICATIONS

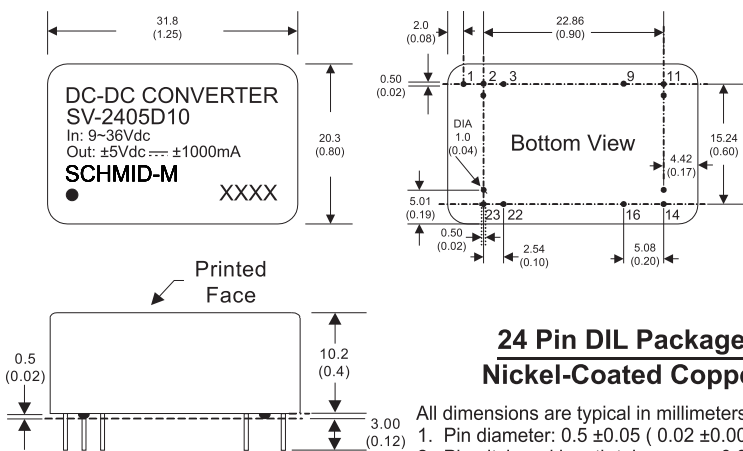

24 Pin DIL Package Nickel-Coated Copper

- All dimensions are typical in millimeters (inches).
1. Pin diameter: 0.5 ±0.05 (0.02 ±0.002)
 2. Pin pitch and length tolerance: ±0.35 (±0.014)
 3. Case Tolerance: ±0.5 (±0.02)
 4. Stand-off tolerance: ±0.1 (±0.004)

PIN CONNECTIONS		
PIN NUMBER	SINGLE	DUAL
1	Remote On/Off	Remote On/Off
2	-V Input	-V Input
3	-V Input	-V Input
9	N.P.	Common
11	N.C.	-V Output
14	+V Output	+V Output
16	-V Output	Common
22	+V Input	+V Input
23	+V Input	+V Input

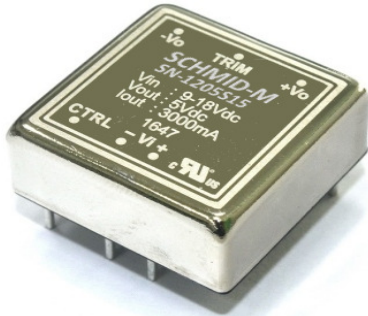

FEATURES

- Wide 2:1 Input Range
- Full SMD Technology
- Soft Start
- No Minimum Load Required
- Efficiency up to 89%
- Adjustable Output Voltage
- Remote On/Off Control (CTRL)
- Over Current Protection
- Over Voltage Protection
- 1600 VDC Isolation
- Operating Temperature Range -40 ~ 85°C max.

MODEL SELECTION GUIDE

MODEL NUMBER	INPUT Voltage Range (Vdc)	INPUT Current		OUTPUT Voltage (Vdc)	OUTPUT Current		EFFICIENCY @FL(%)	Capacitor Load(uF)
		No-Load (mA)	Full Load (mA)		Nin. load (mA)	Full load (mA)		
SN-123R3S15	9-18	20	1310	3.3	0	4000	85	1000
SN-1205S15	9-18	20	1471	5	0	3000	86	1000
SN-1212S15	9-18	20	1494	12	0	1300	88	330
SN-1215S15	9-18	20	1420	15	0	1000	89	220
SN-243R3S15	18-36	15	647	3.3	0	4000	86	1000
SN-2405S15	18-36	15	727	5	0	3000	87	1000
SN-2412S15	18-36	15	747	12	0	1300	88	330
SN-2415S15	18-36	15	710	15	0	1000	89	220
SN-483R3S15	36-75	10	327	3.3	0	4000	85	1000
SN-4805S15	36-75	10	368	5	0	3000	86	1000
SN-4812S15	36-75	10	374	12	0	1300	88	330
SN-4815S15	36-75	10	359	15	0	1000	88	220
SN-1205D15	9-18	20	1488	±5	0	±1500	85	±470
SN-1212D15	9-18	20	1420	±12	0	±625	89	±220
SN-1215D15	9-18	20	1437	±15	0	±500	89	±100
SN-2405D15	18-36	15	744	±5	0	±1500	85	±470
SN-2412D15	18-36	15	718	±12	0	±625	88	±220
SN-2415D15	18-36	15	710	±15	0	±500	89	±100
SN-4805D15	36-75	10	377	±5	0	±1500	84	±470
SN-4812D15	36-75	10	363	±12	0	±625	87	±220
SN-4815D15	36-75	10	359	±15	0	±500	88	±100

MECHANICAL SPECIFICATIONS

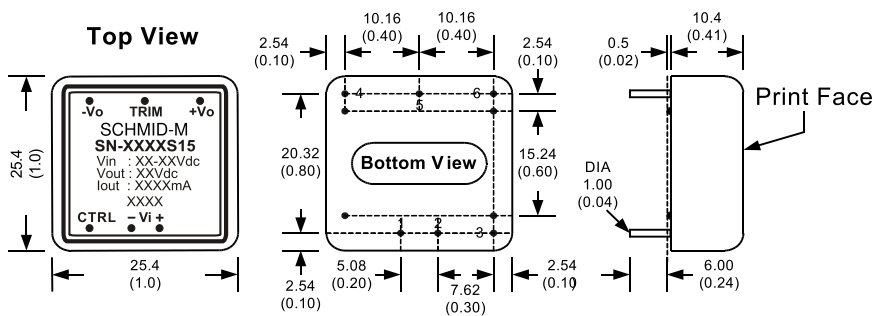

PIN CONNECTIONS		
PIN NUMBER	SINGLE	DUAL
1	+Vin	+Vin
2	-Vin	-Vin
3	CTRL	CTRL
4	+Vout	+Vout
5	Trim	Com
6	-Vout	-Vout

EXTERNAL OUTPUT TRIMMING

Output can be externally trimmed by using the method as below. (single output models only)

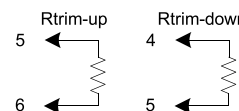

- All dimensions are typical in millimeters (inches).
1. Pin diameter: 1.0 ±0.05 (0.04 ±0.002)
 2. Pin pitch and length tolerance: ±0.35 (±0.014)
 3. Case Tolerance: ±0.5 (±0.02)
 4. Stand-off tolerance: ±0.1 (±0.004)

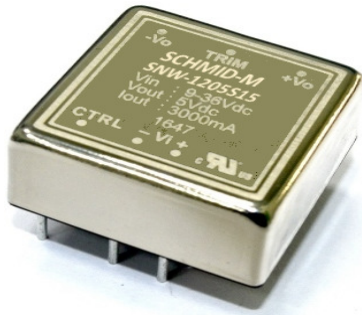

FEATURES

- Ultra Wide 4:1 Input Range
- Soft Start
- 1600 VDC Isolation
- Efficiency up to 89%
- Extended Operating Temperature Range -40 ~ 85°C max.
- Adjustable Output Voltage
- Remote On/Off Control (CTRL)
- Over Current Protection
- Over Voltage Protection
- No Minimum Load Required
- 50% Volume than traditional products

MODEL SELECTION GUIDE

MODEL NUMBER	INPUT Voltage Range (Vdc)	INPUT Current		OUTPUT Voltage (Vdc)	OUTPUT Current		EFFICIENCY @FL(%)	Capacitor Load(uF)
		No-Load (mA)	Full Load (mA)		Min. load (mA)	Full load (mA)		
SNW-243R3S15	9-36	15	647	3.3	0	4000	86	1000
SNW-2405S15	9-36	15	727	5	0	3000	87	1000
SNW-2412S15	9-36	15	747	12	0	1300	88	330
SNW-2415S15	9-36	15	710	15	0	1000	89	220
SNW-483R3S15	18-75	10	331	3.3	0	4000	84	1000
SNW-4805S15	18-75	10	368	5	0	3000	86	1000
SNW-4812S15	18-75	10	378	12	0	1300	87	330
SNW-4815S15	18-75	10	360	15	0	1000	88	220
SNW-2405D15	9-36	15	744	±5	0	±1500	85	±470
SNW-2412D15	9-36	15	718	±12	0	±625	88	±220
SNW-2415D15	9-36	15	710	±15	0	±500	89	±100
SNW-4805D15	18-75	10	376	±5	0	±1500	84	±470
SNW-4812D15	18-75	10	363	±12	0	±625	87	±220
SNW-4815D15	18-75	10	359	±15	0	±500	88	±100

MECHANICAL SPECIFICATIONS

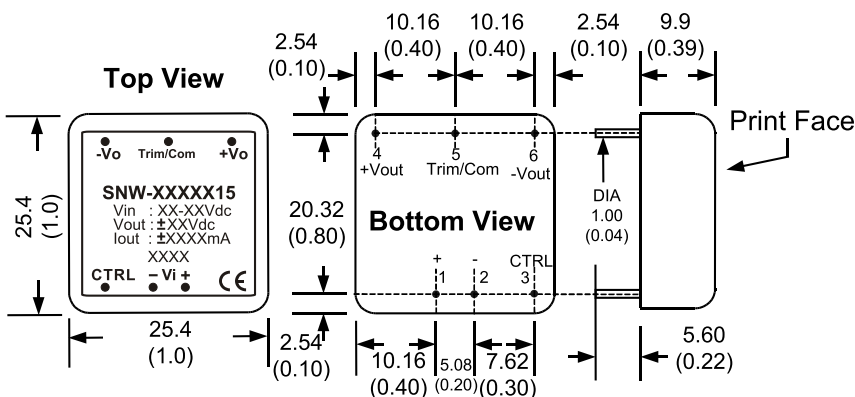

PIN CONNECTIONS		
PIN NUMBER	SINGLE	DUAL
1	+Vin	+Vin
2	-Vin	-Vin
3	CTRL	CTRL
4	+Vout	+Vout
5	Trim	Com
6	-Vout	-Vout

EXTERNAL OUTPUT TRIMMING

Output can be externally trimmed by using the method as below. (single output models only)

Rtrim-up (pins 5, 6)
 Rtrim-down (pins 4, 5)

All dimensions are typical in millimeters (inches).

1. Pin diameter: 1.0 ±0.05 (0.04 ±0.002)
2. Pin pitch tolerance: ±0.35 (±0.014)
3. Case Tolerance: ±0.5 (±0.02)



Features

- Ultra Wide 2:1 Input Range
- Full SMD Technology
- 1600 VDC Isolation
- Efficiency up to 92%
- Extended Operating Temperature Range -40 ~ 75°C max.
- Adjustable Output Voltage
- Remote On/Off Control (CTRL)
- Continuous Short Circuit Protection
- Over Current Protection
- Over Voltage Protection
- Over Temperature Protection
- Soft Start
- Optional Heat-sink

MODEL SELECTION GUIDE

also available in dual output

MODEL NUMBER	INPUT Voltage Range (Vdc)	INPUT Current		OUTPUT Voltage (Vdc)	OUTPUT Current		EFFICIENCY @FL(%)	Capacitor Load(uF)
		No-Load (mA)	Full Load (mA)		Min-Load (mA)	Full Load (mA)		
ST-123R3S30	9-18	80	2426	3.3	0	8000	89	20000
ST-1205S30	9-18	180	2874	5	0	6000	91	14000
ST-125R1S30	9-18	160	2874	5.1	0	6000	92	14000
ST-1212S30	9-18	30	2809	12	0	2500	91	2000
ST-1215S30	9-18	30	2809	15	0	2000	92	2000
ST-243R3S30	18-36	70	1185	3.3	0	8000	91	20000
ST-2405S30	18-36	100	1420	5	0	6000	92	14000
ST-245R1S30	18-36	100	1448	5.1	0	6000	92	14000
ST-2412S30	18-36	20	1436	12	0	2500	92	2000
ST-2415S30	18-36	40	1420	15	0	2000	92	2000
ST-483R3S30	36-75	50	593	3.3	0	8000	90	20000
ST-4805S30	36-75	70	702	5	0	6000	91	14000
ST-485R1S30	36-75	70	724	5.1	0	6000	91	14000
ST-4812S30	36-75	30	718	12	0	2500	91	2000
ST-4815S30	36-75	30	710	15	0	2000	91	2000

MECHANICAL SPECIFICATIONS

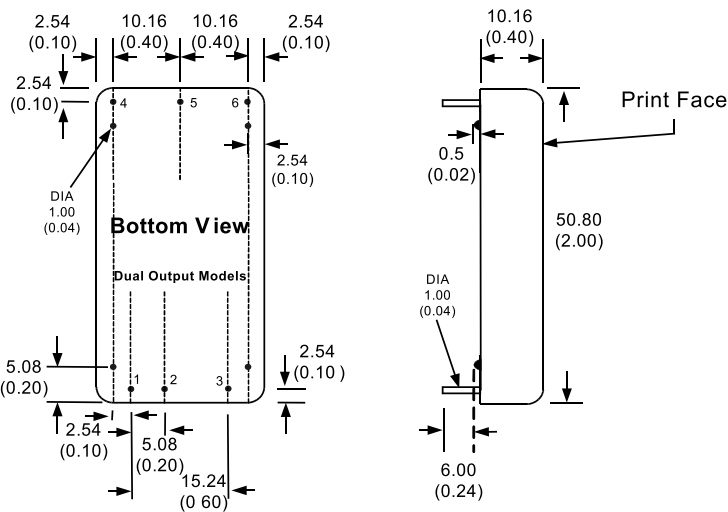

- All dimensions are typical in millimeters (inches).
1. Pin diameter: 1.0 ±0.05 (0.04 ±0.002)
 2. Pin pitch and length tolerance: ±0.35 (±0.014)
 3. Case Tolerance: ±0.5 (±0.02)
 4. Stand-off Tolerance: ±0.1 (±0.004)

PIN CONNECTIONS

PIN NUMBER	SINGLE	DUAL
1	+Vin	+Vin
2	-Vin	-Vin
3	CTRL	CTRL
4	+Vout	+Vout
5	-Vout	Com
6	Trim	-Vout

EXTERNAL OUTPUT TRIMMING

Output can be externally trimmed by using the method as below. (single output models only)

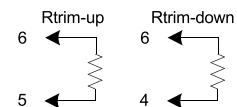



Features

- Ultra Wide 4:1 Input Range
- Full SMD Technology
- 1600 VDC Isolation
- Efficiency up to 91%
- Extended Operating Temperature Range -40 ~ 75°C max.
- Adjustable Output Voltage
- Remote On/Off Control (CTRL)
- Continuous Short Circuit Protection
- Over Current Protection
- Over Voltage Protection
- Over Temperature Protection
- Soft Start
- Optional Heat-sink

MODEL SELECTION GUIDE

also available in dual output & triple output

MODEL NUMBER	INPUT Voltage Range (Vdc)	INPUT Current		OUTPUT Voltage (Vdc)	OUTPUT Auxiliary (Vdc)	OUTPUT Current		EFFICIENCY @FL (% , typ.)	Capacitor Load @FL (µF, max.)
		No-Load (mA, max.)	Full Load (mA, typ.)			Min. load (mA)	Full load (mA)		
STW-243R3S30	9-36	100	1199	3.3		0	7500	89	20000
STW-2405S30	9-36	100	1437	5		0	6000	90	14000
STW-245R1S30	9-36	100	1465	5.1		0	6000	90	14000
STW-2412S30	9-36	50	1453	12		0	2500	89	2000
STW-2415S30	9-36	50	1453	15		0	2000	89	2000
STW-483R3S30	18-75	100	599	3.3		0	7500	89	20000
STW-4805S30	18-75	100	718	5		0	6000	90	14000
STW-485R1S30	18-75	100	732	5.1		0	6000	90	14000
STW-4812S30	18-75	50	718	12		0	2500	90	2000
STW-4815S30	18-75	50	710	15		0	2000	91	2000

MECHANICAL SPECIFICATIONS

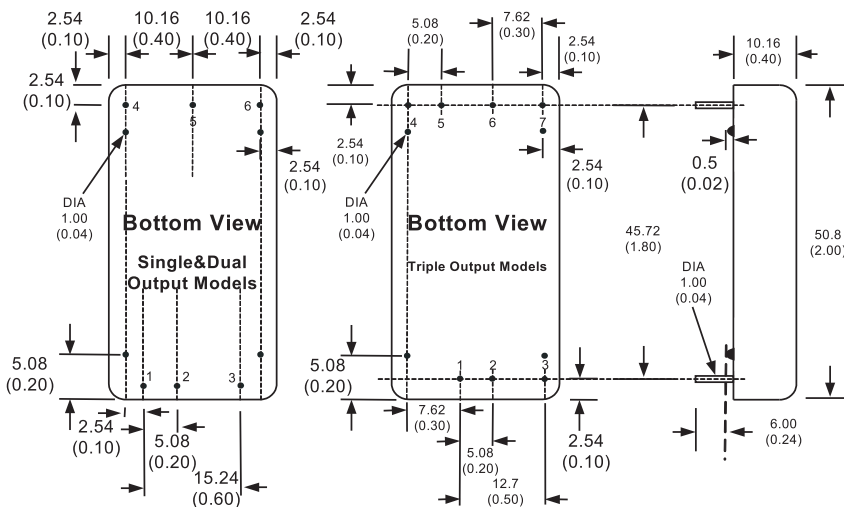

- All dimensions are typical in millimeters (inches).
1. Pin diameter: 1.0 ±0.05 (0.04 ±0.002)
 2. Pin pitch and length tolerance: ±0.35 (±0.014)
 3. Case Tolerance: ±0.5 (±0.02)
 4. Stand-off tolerance: ±0.1 (±0.004)

PIN CONNECTIONS

PIN NUMBER	SINGLE	DUAL	Triple
1	+Vin	+Vin	+Vin
2	-Vin	-Vin	-Vin
3	CTRL	CTRL	CTRL
4	+Vout	+Vout	+Aux
5	-Vout	Com	-Aux
6	Trim	-Vout	Com
7	No pin	No pin	+Vout

EXTERNAL OUTPUT TRIMMING

Output can be externally trimmed by using the method as below. (single output models only)

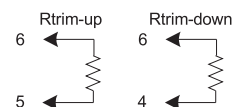



Features

- Wide 2:1 Input Range
- 1600 VDC Isolation
- Efficiency up to 92%
- Extended Operating Temperature: -40 ~ 71°C max.
- Adjustable Output Voltage
- Remote On/Off Control (CTRL)
- Continuous Short Circuit Protection
- Over Load Protection
- Over Voltage Protection
- Soft Start
- High Power Density: 40W in 2"x1"x0.4" package
- No Minimum Load Required

MODEL SELECTION GUIDE

MODEL NUMBER	INPUT Voltage Range (Vdc)	INPUT Current		OUTPUT Voltage (Vdc)	OUTPUT Current		EFFICIENCY @FL(%)	Capacitor Load(µF)
		No-Load (mA)	Full Load (mA)		Min-Load (mA)	Full Load (mA)		
ST-123R3S40	9-18	100	2444	3.3	0	8000	90	21800
ST-1205S40	9-18	160	3663	5	0	8000	91	13600
ST-1212S40	9-18	40	3663	12	0	3333	91	2300
ST-1215S40	9-18	50	3663	15	0	2666	91	1500
ST-243R3S40	18-36	60	1208	3.3	0	8000	91	21800
ST-2405S40	18-36	90	1811	5	0	8000	92	13600
ST-2412S40	18-36	30	1831	12	0	3333	91	2300
ST-2415S40	18-36	40	1811	15	0	2666	92	1500
ST-483R3S40	36-75	40	604	3.3	0	8000	91	21800
ST-4805S40	36-75	60	905	5	0	8000	92	13600
ST-4812S40	36-75	20	915	12	0	3333	91	2300
ST-4815S40	36-75	20	905	15	0	2666	92	1500
ST-1212D40	9-18	50	3663	±12	0	±1666	91	±1200
ST-4815D40	36-75	40	906	±15	0	±1333	92	±750

MECHANICAL SPECIFICATIONS

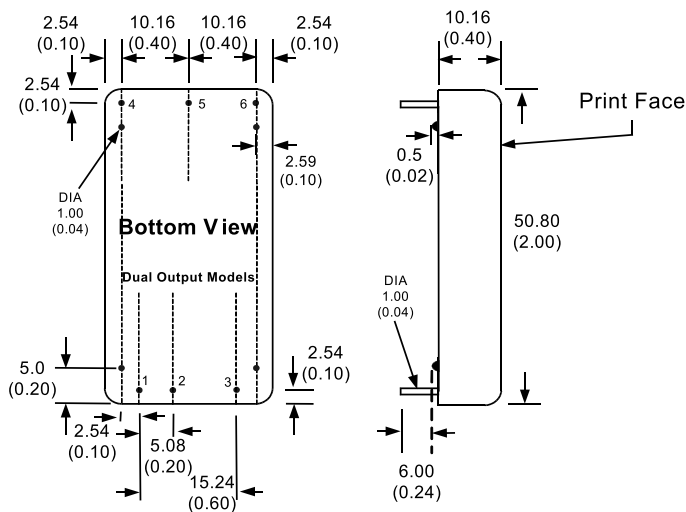

PIN CONNECTIONS		
PIN NUMBER	SINGLE	DUAL
1	+Vin	+Vin
2	-Vin	-Vin
3	CTRL	CTRL
4	+Vout	+Vout
5	-Vout	Com
6	Trim	-Vout

- All dimensions are typical in millimeters (inches).
1. Pin diameter: 1.0 ±0.05 (0.04 ±0.002)
 2. Pin pitch and length tolerance: ±0.35 (±0.014)
 3. Case Tolerance: ±0.5 (±0.02)
 4. Stand-off Tolerance: ±0.1 (±0.004)

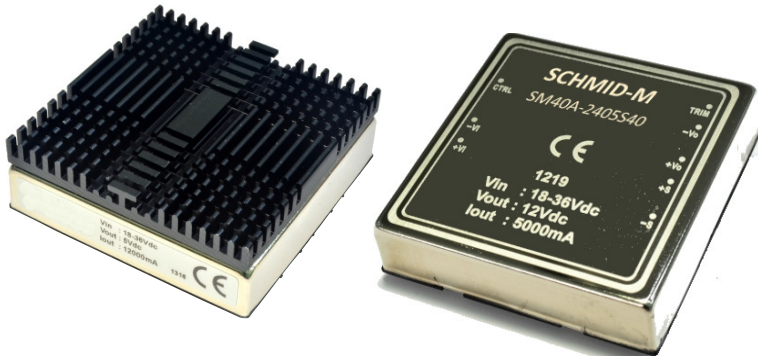

Features

- Wide 4:1 Input Range
- Full SMD Technology
- 1600 VDC Isolation
- Efficiency up to 92%
- -40 ~ 85°C Operation Temperature Range
- Adjustable Output Voltage
- Remote On/Off Control (CTRL)
- Continuous Short Circuit Protection
- Over Current Protection
- Over Voltage Protection
- Over Temperature Protection
- Soft Start

MODEL SELECTION GUIDE

MODEL NUMBER	INPUT Voltage Range (Vdc)	INPUT Current		OUTPUT Voltage (Vdc)	OUTPUT Current		EFFICIENCY @FL(%)	Capacitor Load(uF)
		No-Load (mA)	Full Load (mA)		Min. load (mA)	Full load (mA)		
SM40A-243R3S40	9-36	80	1598	3.3	0	10000	89	25000
SM40A-2405S40	9-36	100	1893	5	0	8000	91	13000
SM40A-2412S40	9-36	50	1925	12	0	3350	90	2300
SM40A-2415S40	9-36	50	1904	15	0	2650	90	1500
SM40A-483R3S40	18-75	60	799	3.3	0	10000	89	25000
SM40A-4805S40	18-75	60	936	5	0	8000	92	13000
SM40A-4812S40	18-75	30	963	12	0	3350	90	2300
SM40A-4815S40	18-75	30	941	15	0	2650	91	1500
SM40A-2412D40	9-36	60	1919	±12	0	±1650	89	±1200
SM40A-2415D40	9-36	60	1962	±15	0	±1350	89	±750
SM40A-4812D40	18-75	30	948	±12	0	±1650	90	±1200
SM40A-4815D40	18-75	30	970	±15	0	±1350	90	±750

MECHANICAL SPECIFICATIONS

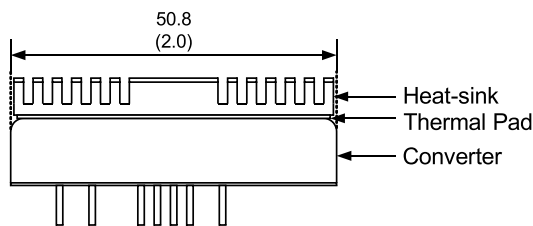
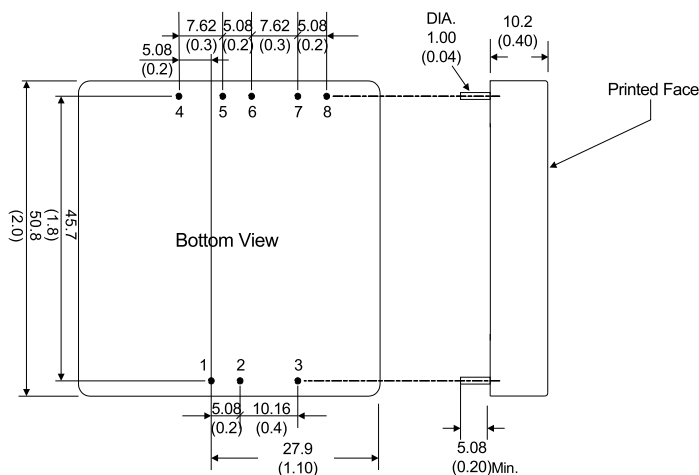

- All dimensions are typical in millimeters (inches).
1. Pin diameter: 1.0 ±0.05 (0.04 ±0.002)
 2. Pin pitch and length tolerance: ±0.35 (±0.014)
 3. Case Tolerance: ±0.5 (±0.02)

PIN CONNECTIONS		
PIN NUMBER	SINGLE	DUAL
1	+Vin	+Vin
2	-Vin	-Vin
3	CTRL	CTRL
4	-Sense	+Vout
5	+Sense	Com
6	+Vout	Com
7	-Vout	-Vout
8	Trim	Trim

EXTERNAL OUTPUT TRIMMING

Output can be externally trimmed by using the method as below. () for dual output trim.



Features

- Wide 2:1 Input Range
- 11600 VDC Isolation
- Efficiency up to 92.5%
- Adjustable Output Voltage
- Remote On/Off Control (CTRL)
- Continuous Short Circuit Protection
- Over Current Protection
- Over Voltage Protection
- Over Temperature Protection
- Extended Operating Temperature Range -40 ~ 95° C max.
- Soft Start
- Built-in EMC filter meets EN55032 ClassA without external components

MODEL SELECTION GUIDE

MODEL NUMBER	INPUT Voltage Range (Vdc)	INPUT Current		OUTPUT Voltage (Vdc)	OUTPUT Current		EFFICIENCY @FL (% , typ.)	Capacitor Load @FL (µF, max.)
		No-Load (mA, max.)	Full Load (mA, typ.)		Min. load (mA)	Full load (mA)		
ST-123R3S50	9-18, 12V Nominal	120	3022	3.3	0	10000	91	26000
ST-1205S50	9-18, 12V Nominal	170	4579	5	0	10000	91	17000
ST-1212S50	9-18, 12V Nominal	50	4682	12	0	4167	89	3300
ST-1215S50	9-18, 12V Nominal	50	4630	15	0	3333	90	2200
ST-243R3S50	18-36, 24V Nominal	70	1494	3.3	0	10000	92	26000
ST-2405S50	18-36, 24V Nominal	90	2252	5	0	10000	92.5	17000
ST-2412S50	18-36, 24V Nominal	40	2277	12	0	4167	91.5	3300
ST-2415S50	18-36, 24V Nominal	30	2277	15	0	3333	91.5	2200
ST-483R3S50	36-75, 48V Nominal	50	747	3.3	0	10000	92	26000
ST-4805S50	36-75, 48V Nominal	60	1126	5	0	10000	92.5	17000
ST-4812S50	36-75, 48V Nominal	30	1145	12	0	4167	91	3300
ST-4815S50	36-75, 48V Nominal	40	1138	15	0	3333	91.5	2200

MECHANICAL SPECIFICATIONS

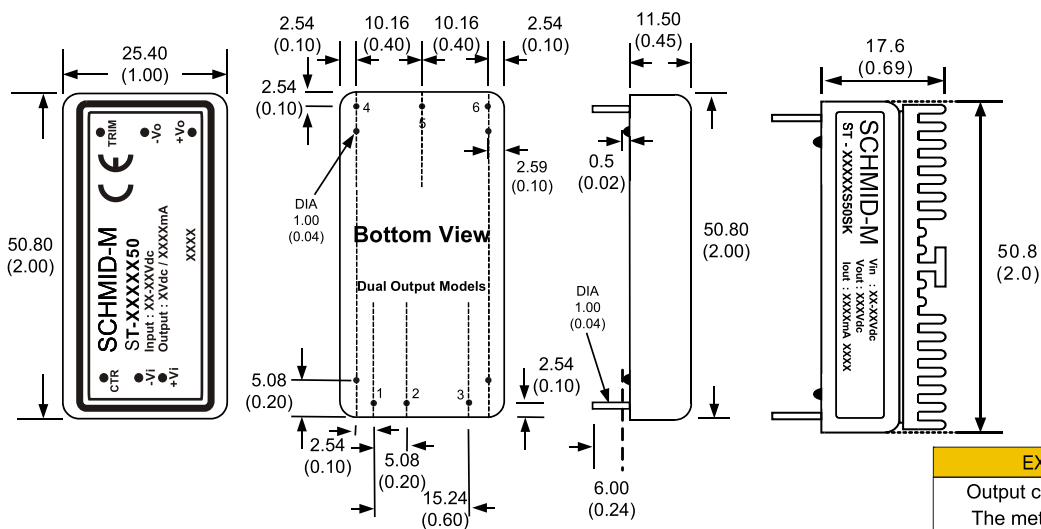

PIN CONNECTIONS	
PIN NUMBER	SINGLE
1	+Vin
2	-Vin
3	CTRL
4	+Vout
5	-Vout
6	Trim

EXTERNAL OUTPUT TRIMMING

Output can be externally trimmed by using The method as below.

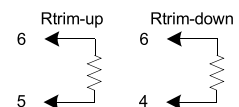

All dimensions are typical in millimeters (inches).

1. Pin diameter: 1.0 ±0.05 (0.04 ±0.002)
2. Pin pitch and length tolerance: ±0.35 (±0.014)
3. Case Tolerance: ±0.5 (±0.02)
4. Stand-off Tolerance: ±0.1 (±0.004)



Features

- Wide 4:1 Input Range
- 1600 VDC Isolation
- Efficiency up to 93%
- Extended Operating Temperature Range -40 ~ 100°C max.
- Adjustable Output Voltage
- Remote On/Off Control (CTRL)
- Continuous Short Circuit Protection
- Over Current Protection
- Over Voltage Protection
- Over Temperature Protection
- Soft Start
- No minimum load required

MODEL SELECTION GUIDE

MODEL NUMBER	INPUT Voltage Range (Vdc)	INPUT Current		OUTPUT Voltage (Vdc)	OUTPUT Current		EFFICIENCY @FL (% , typ.)	Capacitor Load @FL (μF, max.)
		No-Load (mA, max.)	Full Load (mA, typ.)		Min. load (mA)	Full load (mA)		
STW-2405S60	9-36, 24V Nominal	25	2703	5	0	12000	92.5	30000
STW-2412S60	9-36, 24V Nominal	25	2703	12	0	5000	92.5	5850
STW-2415S60	9-36, 24V Nominal	25	2688	15	0	4000	93	3900
STW-4805S60	18-75, 48V Nominal	25	1344	5	0	12000	93	30000
STW-4812S60	18-75, 48V Nominal	25	1351	12	0	5000	92.5	5850
STW-4815S60	18-75, 48V Nominal	25	1344	15	0	4000	93	3900
STW-2412D60	9-36, 24V Nominal	40	2747	±12	0	±2500	91	±3900
STW-2415D60	9-36, 24V Nominal	50	2747	±15	0	±2000	91	±2400
STW-4812D60	18-75, 48V Nominal	40	1373	±12	0	±2500	91	±3900
STW-4815D60	18-75, 48V Nominal	50	1373	±15	0	±2000	91	±2400

MECHANICAL SPECIFICATIONS

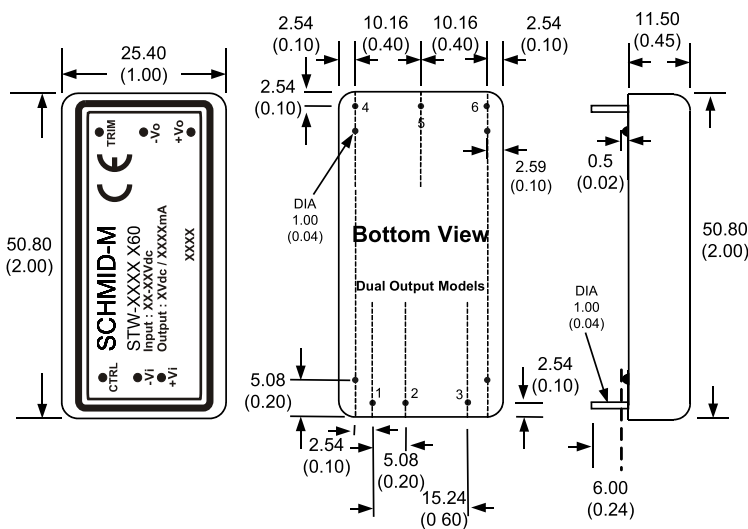

- All dimensions are typical in millimeters (inches).
1. Pin diameter: 1.0 ±0.05 (0.04 ±0.002)
 2. Pin pitch and length tolerance: ±0.35 (±0.014)
 3. Case Tolerance: ±0.5 (±0.02)
 4. Stand-off Tolerance: ±0.1 (±0.004)

PIN CONNECTIONS		
PIN NUMBER	SINGLE	DUAL
1	+Vin	+Vin
2	-Vin	-Vin
3	CTRL	CTRL
4	+Vout	+Vout
5	-Vout	Com
6	Trim	-Vout

EXTERNAL OUTPUT TRIMMING

Output can be externally trimmed by using the method as below. (single output models only)

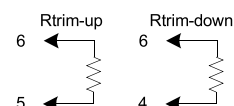

SURF24_QB-100 DC/DC Converter



Series with suffix "H" are heat sink mounting;

Features

- Ultra wide input voltage range (4:1)
- High efficiency up to 90%
- Isolation voltage: 2.25K VDC
- Input under-voltage protection, output short circuit, over-current, over-voltage, over-temperature protection
- Operating temperature range: -40°C to +85°C
- Five-sided metal shielding package
- International standard pin-out: 1/4 brick
- Meets requirements of railway standard EN50155

Selection Guide

Part No. ^①	Input Voltage (VDC)		Output		Efficiency (%Min./Typ.) @ Full Load	Max. Capacitive Load(μF)
	Nominal (Range)	Max. ^②	Output Voltage(VDC)	Output Current (A)(Max.)		
SURF2405QB-100W(F/H)R3	24 (9-36)	40	5	20	87/89	6000
SURF2412QB-100W(F/H)R3			12	8.3	88/90	2000
SURF2415QB-100W(F/H)R3			15	6.7	88/90	2000
SURF2424QB-100W(F/H)R3			24	4.2	88/90	1000
SURF2428QB-100W(F/H)R3			28	3.6	88/90	1000
SURF2448QB-100W(F/H)R3			48	2.1	88/90	470

Note:

① "F" means product with aluminium bottom case; Series with suffix "H" are heat sink mounting; If the application has a higher requirement for heat dissipation, you can choose modules with heat sink;

② Exceeding the maximum input voltage may cause permanent damage.

MECHANICAL SPECIFICATIONS

THIRD ANGLE PROJECTION

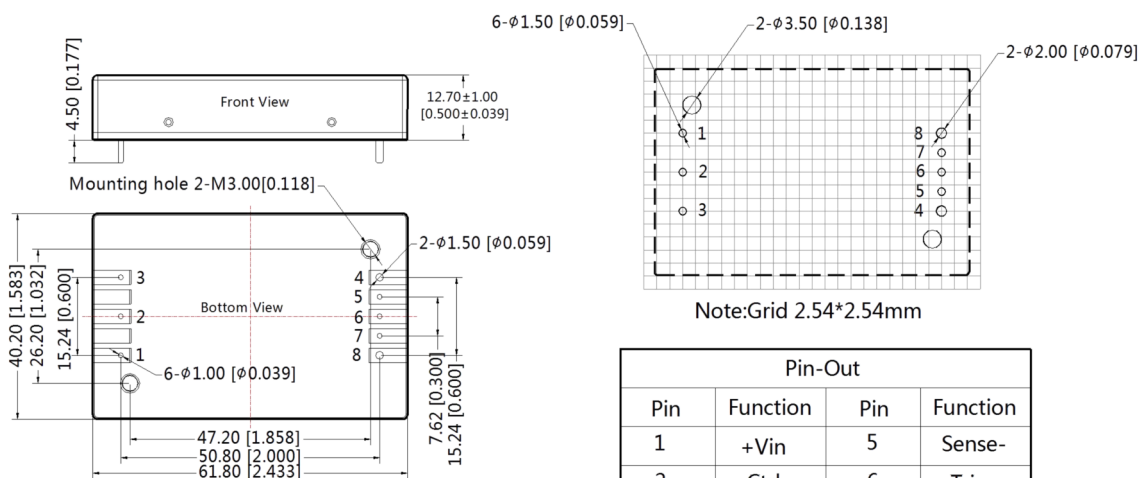

Note:

Unit: mm[inch]

Pin1, 2, 3, 5, 6, 7's diameter: 1.00[0.039]

Pin4, 8's diameter: 1.50[0.059]

Pin diameter tolerances: ±0.10[±0.004]

General tolerances: ±0.50[±0.020]

Mounting hole screwing torque: Max 0.4 N·m

Pin-Out			
Pin	Function	Pin	Function
1	+Vin	5	Sense-
2	Ctrl	6	Trim
3	-Vin	7	Sense+
4	0V	8	+Vo

1102005101-B0

SURF48_QB-200 DC/DC Converter

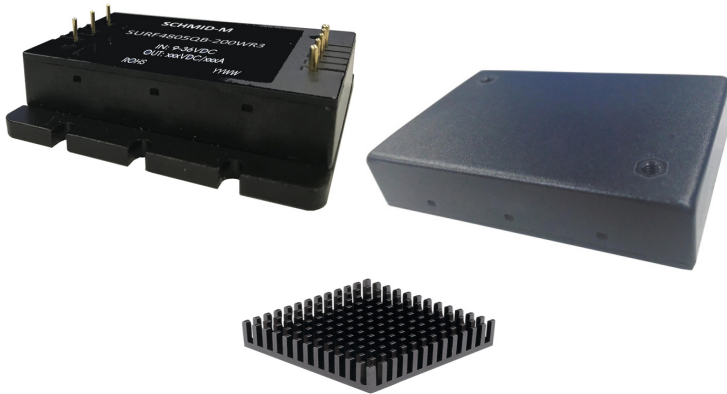

Series with suffix "H" are heat sink mounting;

Features

- Ultra wide input voltage range (4:1)
- High efficiency up to 91%
- Isolation voltage: 2.25K VDC
- Input under-voltage protection, Output short circuit, over-current, over-voltage, over-temperature protection
- Operating temperature range: -40°C to +85°C
- Five-sided metal shielding package
- International standard pin-out: 1/4 brick

Selection Guide

Part No.	Input Voltage (VDC)		Output		Efficiency (%Min./Typ.) @ Full Load	Max. Capacitive Load(μF)
	Nominal (Range)	Max. [Ⓟ]	Output Voltage(VDC)	Output Current (A)(Max.)		
SURF4805QB-200W(F/H)R3	48 (18-75)	80	5	40	86/88	6000
SURF4812QB-200W(F/H)R3			12	16.7	89/91	2000
SURF4815QB-200W(F/H)R3			15	13.3	87/89	2000
SURF4824QB-200W(F/H)R3			24	8.4	89/91	1000
SURF4848QB-200W(F/H)R3			48	4.2	89/91	450

Note: ① Exceeding the maximum input voltage may cause permanent damage.

THIRD ANGLE PROJECTION

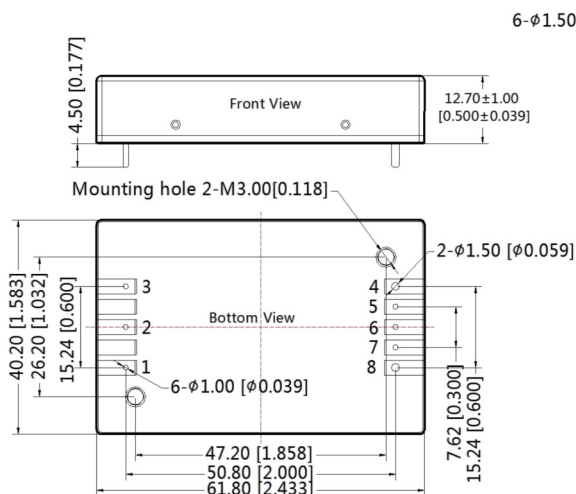

Note:
 Unit: mm[inch]
 Pin1, 2, 3, 5, 6, 7's diameter: 1.00[0.039]
 Pin4, 8's diameter: 1.50[0.059]
 Pin diameter tolerances: ±0.10[±0.004]
 General tolerances: ±0.50[±0.020]
 Mounting hole screwing torque: Max 0.4 N·m

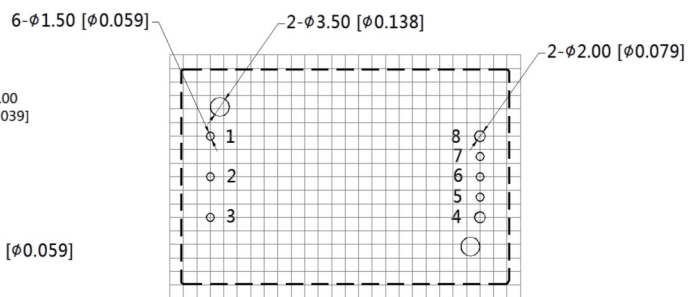

Note: Grid 2.54*2.54mm

Pin-Out			
Pin	Function	Pin	Function
1	+Vin	5	Sense-
2	Ctrl	6	Trim
3	-Vin	7	Sense+
4	0V	8	+Vo

1102005101-B0

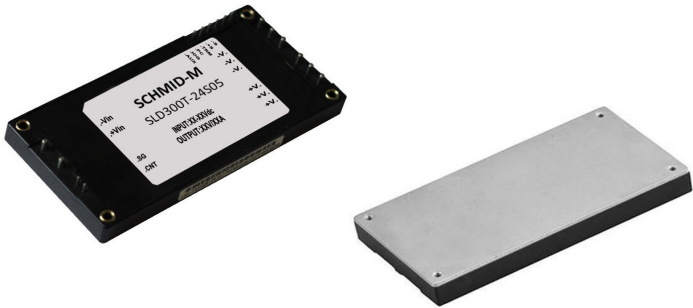

Features

- Wide Input voltage range (2:1)
- Typical Efficiency:85%
- Switching frequency: 300KHz
- Output Over current protect, Short circuit protection
- input under voltage protection, over voltage protection
- input-output isolated
- PCB Board in-line type installs
- High reliability
- Optional heat sink

Product Program			
PART #	Input voltage range	VO1	
		V	A
SLD300T-24S05	24 V(18~36V)	5	60
SLD300T-24S12		12	25
SLD300T-24S15		15	20
SLD300T-24S24		24	12.5
SLD300T-24S28		28	10.7
SLD300T-24S36		36	8.3
SLD300T-24S48		48	6.25
SLD300T-48S05	48V(36~72V)	5	60
SLD300T-48S12		12	25
SLD300T-48S15		15	20
SLD300T-48S24		24	12.5
SLD300T-48S28		28	10.7
SLD300T-48S36		36	8.3
SLD300T-48S48	48	6.25	
SLD300T-110S12	110V(72~144V)	12	25
SLD300T-110S15		15	20
SLD300T-110S24		24	12.5
SLD300T-110S28		28	10.7
SLD300T-110S36		36	8.3
SLD300T-110S48		48	6.25

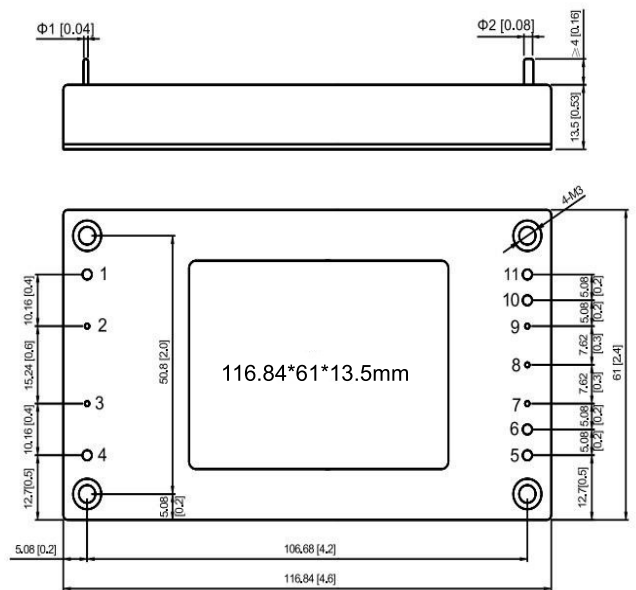

PIN CONNECTIONS	
PIN NUMBER	SINGLE
1	-Vin
2	Case
3	REM
4	+Vin
5	+Vout
6	+Vout
7	+S
8	TRIM
9	-S
10	-Vout
11	-Vout

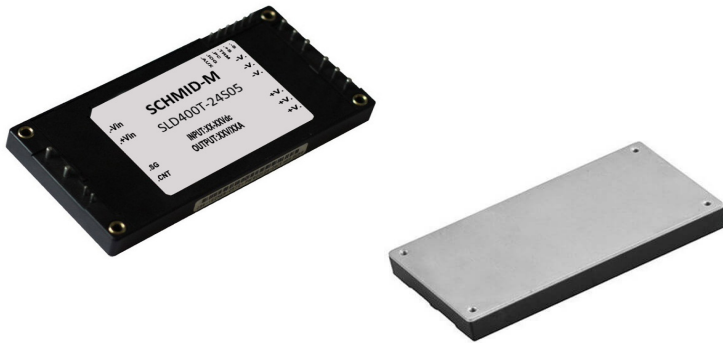

Features

- Wide Input voltage range (2:1)
- Typical Efficiency:85%
- Switching frequency: 300KHz
- Output Over current protect, Short circuit protection
- input under voltage protection, over voltage protection
- input-output isolated
- PCB Board in-line type installs
- High reliability
- Optional heat sink

Product Program			
PART #	Input voltage range	VO1	
		V	A
SLD400T-24S05	24 V(18~36V)	5	80
SLD400T-24S12		12	33.3
SLD400T-24S15		15	26.7
SLD400T-24S24		24	16.7
SLD400T-24S28		28	14.3
SLD400T-24S36		36	11.1
SLD400T-24S48		48	8.3
SLD400T-48S05		48V(36~72V)	5
SLD400T-48S12	12		33.3
SLD400T-48S15	15		26.7
SLD400T-48S24	24		16.7
SLD400T-48S28	28		14.3
SLD400T-48S36	36		11.1
SLD400T-48S48	48		8.3
SLD400T-110S12	110V(72~144V)		12
SLD400T-110S15		15	26.7
SLD400T-110S24		24	16.7
SLD400T-110S28		28	14.3
SLD400T-110S36		36	11.1
SLD400T-110S48		48	8.3

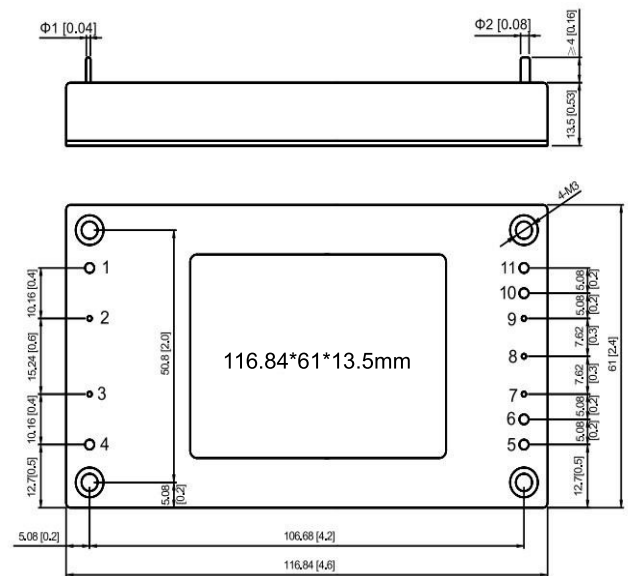

PIN CONNECTIONS	
PIN NUMBER	SINGLE
1	-Vin
2	Case
3	REM
4	+Vin
5	+Vout
6	+Vout
7	+S
8	TRIM
9	-S
10	-Vout
11	-Vout



Features

- High efficiency up to 95%
- No-load input current as low as 0.2mA
- Operating temperature range: -40°C to +85°C
- Output short circuit protection
- SMD package
- Meets EN62368 standards (Pending)

Selection Guide

Certification	Part Number	Input Voltage (VDC)	Output		Efficiency (%/Typ.) (Min. Vin)/ (Max. Vin) @Full Load	Max. Capacitive Load(μF)
		Nominal (Range)	Output Voltage (VDC)	Max. Output Current (mA)		
CE (Pending)	SK7801T-500R3	12 (4.75-28)	1.5	500	76/67	680
	SK78X2T-500R3	12 (4.75-28)	1.8	500	76/69	680
	SK7802T-500R3	12 (4.75-32)	2.5	500	81/74	680
	SK7803T-500R3	24 (4.75-36)	3.3	500	86/80	680
	SK7805T-500R3	24 (6.5-36)	5	500	90/84	680
	SK78X6T-500R3	24 (8-36)	6.5	500	92/87	680
	SK7809T-500R3	24 (12-36)	9	500	93/90	680
	SK7812T-500R3	24 (15-36)	12	500	94/91	680
	SK7815T-500R3	24 (19-36)	15	500	95/93	680

Note: For input voltage higher than 30 VDC, a 22μF/50V input capacitor is required.

MECHANICAL SPECIFICATIONS

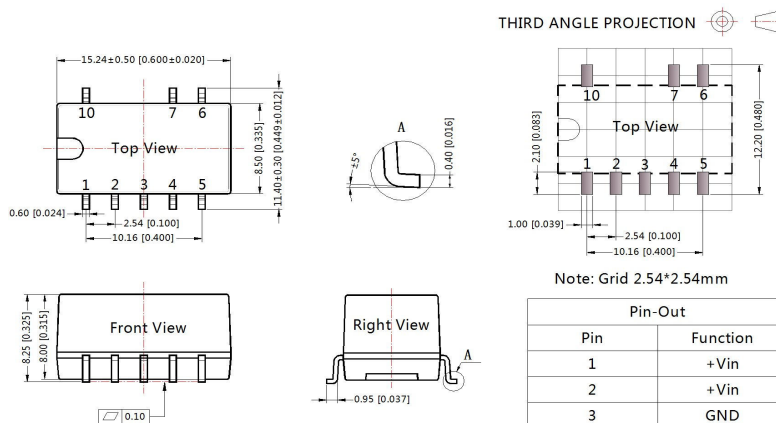

Note: Grid 2.54*2.54mm

Pin-Out	
Pin	Function
1	+Vin
2	+Vin
3	GND
4	+Vout
5	+Vout
6	V adj
7	GND
10	Remote On/Off

NC: Pin to be isolated from circuitry

2K78TR3000-A0

SK78T-1000R3

Non Isolated
DC/DC Converter



Features

- High efficiency up to 95%
- No-load input current as low as 0.2mA
- Operating temperature range: -40°C to +85°C
- Output short circuit protection
- SMD package
- Meets EN62368 standards (Pending)

Selection Guide

Certification	Part Number	Input Voltage (VDC)	Output		Efficiency (%/Typ.) (Min. Vin)/ (Max. Vin) @Full Load	Max. Capacitive Load(μF)
		Nominal (Range)	Output Voltage (VDC)	Max. Output Current (mA)		
CE (Pending)	SK7801T-1000R3	12 (4.75-32)	1.5	1000	76/66	680
	SK78X2T-1000R3	12 (4.75-32)	1.8	1000	79/69	680
	SK7802T-1000R3	12 (4.75-32)	2.5	1000	86/74	680
	SK7803T-1000R3	24 (6.5-36)	3.3	1000	90/80	680
	SK7805T-1000R3	24 (8-36)	5	1000	93/85	680
	SK78X6T-1000R3	24 (10-36)	6.5	1000	93/86	680
	SK7809T-1000R3	24 (13-36)	9	1000	94/89	680
	SK7812T-1000R3	24 (16-36)	12	800	95/92	680

Note: For input voltage higher than 30 VDC, a 22μF/50V input capacitor is required.

MECHANICAL SPECIFICATIONS

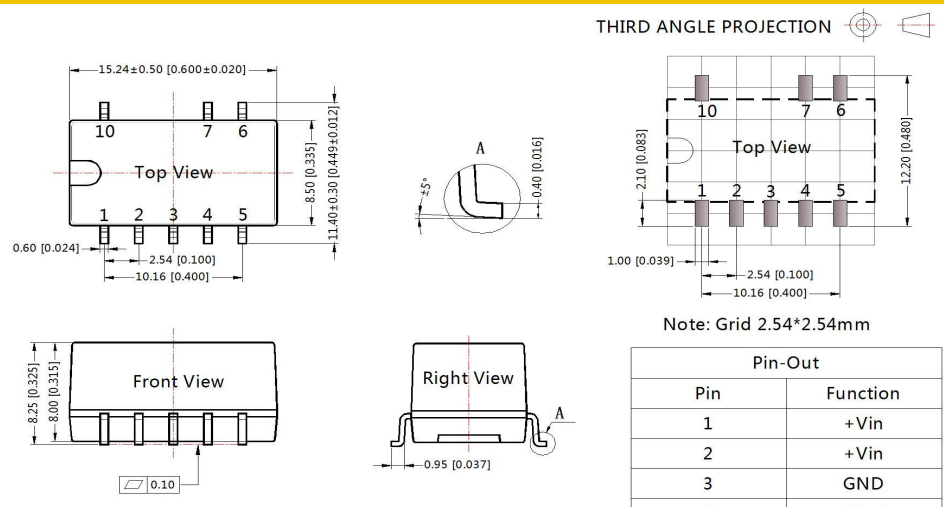

Pin-Out	
Pin	Function
1	+Vin
2	+Vin
3	GND
4	+Vout
5	+Vout
6	V adj
7	GND
10	Remote On/Off

Note:
Unit: mm[inch]
Pin section tolerances: ±0.10[±0.004]
General tolerances: ±0.25[±0.010]

NC: Pin to be isolated from circuitry

2K78TR3000-A0



Features

- High efficiency up to 95%
- No-load input current as low as 0.2mA
- Operating temperature range: -40°C to +85°C
- Support the negative output
- Output short circuit protection
- Pin-out compatible with LM78XX linear regulators
- UL60950,EN60950 approval

Selection Guide

Certification	Part Number	Input Voltage (VDC)	Output		Efficiency (%/Typ.) (Min. Vin)/ (Max. Vin) @Full Load	Max. Capacitive Load(μF)
		Nominal (Range)	Output Voltage (VDC)	Max. Output Current (mA)		
UL/CE	SK7803-500R3	24 (4.75-36)	3.3	500	86/80	680
	SK7805-500R3	24 (6.5-36)	5.0	500	90/84	680
		12 (7-31)	-5.0	-300	80/81	330
	SK7809-500R3	24 (12-36)	9	500	93/90	680
	SK7812-500R3	24 (15-36)	12	500	94/91	680
		12 (8-24)	-12	-150	84/85	330
SK7815-500R3	24 (19-36)	15	500	95/93	680	
	12 (8-21)	-15	-150	85/87	330	

Note: For input voltage higher than 30 VDC, a 22μF/50V Input capacitor is required.

MECHANICAL SPECIFICATIONS

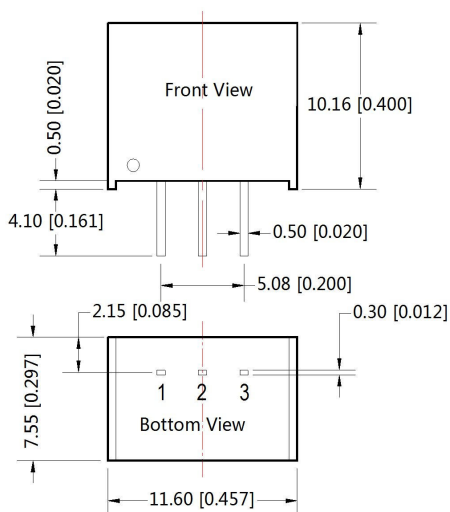

THIRD ANGLE PROJECTION

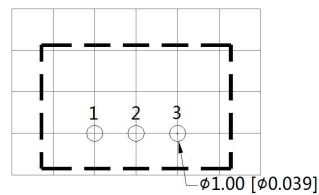

Note : Grid 2.54*2.54mm

Pin	Pin-Out	
	Positive Output	Negative Output
1	Vin	Vin
2	GND	-Vo
3	+Vo	GND

Note:
Unit :mm[inch]
Pin section tolerances:±0.10[±0.004]
General tolerances:±0.25[±0.010]

1100000405-B0

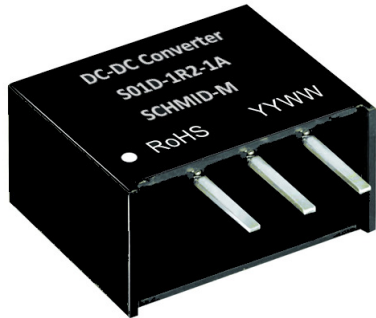

Features

- 3PIN SIP Package
- Pin-out compatible with LM78XX Linears
- UL94V-0 Package Material
- Operating Temperature: -40°C TO +85°C
- Efficiency up to 96%, Non isolated, no need for heatsinks
- Short circuit protection

Selection Guide

Part Number	Input Range	Output Voltage	Output Current	Efficiency	
	Vdc	Vdc	mA	Min. Vin(%)	Max. Vin(%)
S01D-1R2-1A	4.6-36	1.2	1000	74	62
S01D-1R5-1A	4.6-36	1.5	1000	78	65
S01D-1R8-1A	4.6-36	1.8	1000	82	69
S01D-2R5-1A	4.6-36	2.5	1000	87	75
S01D-3R3-1A	4.75-36	3.3	1000	91	78
S01D-05-1A	6.5-36	5.0	1000	92	84
S01D-6R5-1A	9.0-36	6.5	1000	93	87
S01D-09-1A	12-36	9.0	1000	95	90
S01D-12-1A	15-36	12	1000	95	92
S01D-15-1A	18-36	15	1000	96	94

MECHANICAL SPECIFICATIONS

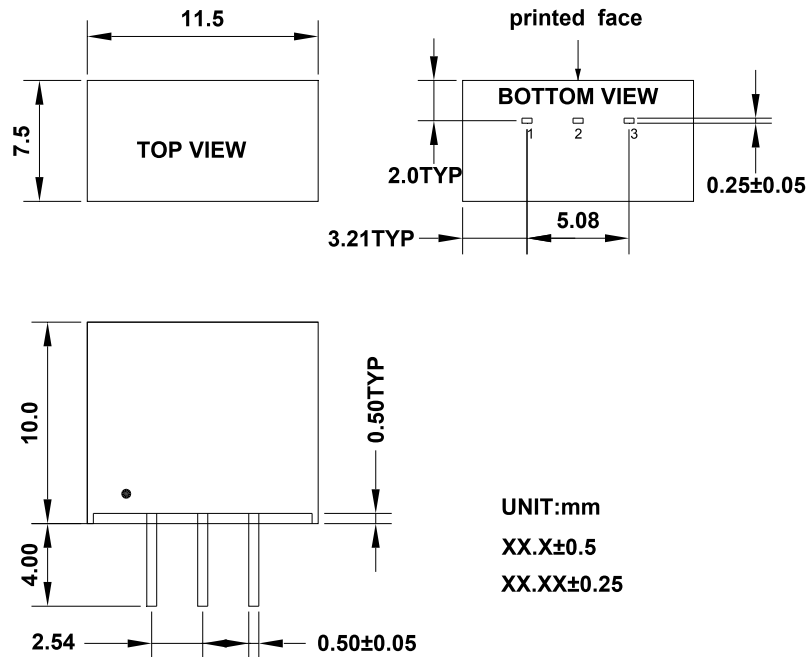

PIN Connection

PIN	1	2	3
SINGLE	+Vin	GND	+Vout



Features

- 3PIN SIP Package
- Pin-out compatible with LM78XX Linears
- UL94V-0 Package Material
- Operating Temperature: -40°C TO +85°C
- Efficiency up to 96%, Non isolated, no need for heatsinks
- Short circuit protection
- Wide input voltage ranges 4.75~36VDC

Selection Guide

Part Number	Input Range	Output Voltage	Output Current	Efficiency	
	Vdc	Vdc	mA	Min. Vin(%)	Max. Vin(%)
S01D-1R8-2A	4.75-36	1.8	2000	89	80
S01D-2R5-2A	4.75-36	2.5	2000	91	83
S01D-3R3-2A	4.75-36	3.3	2000	90	86
S01D-05-2A	6.5-36	5.0	2000	92	89
S01D-6R5-2A	9.0-36	6.5	2000	93	91
S01D-09-2A	12-36	9.0	2000	94	92
S01D-12-2A	15-36	12	2000	95	93
S01D-15-2A	18-36	15	2000	96	94

MECHANICAL SPECIFICATIONS

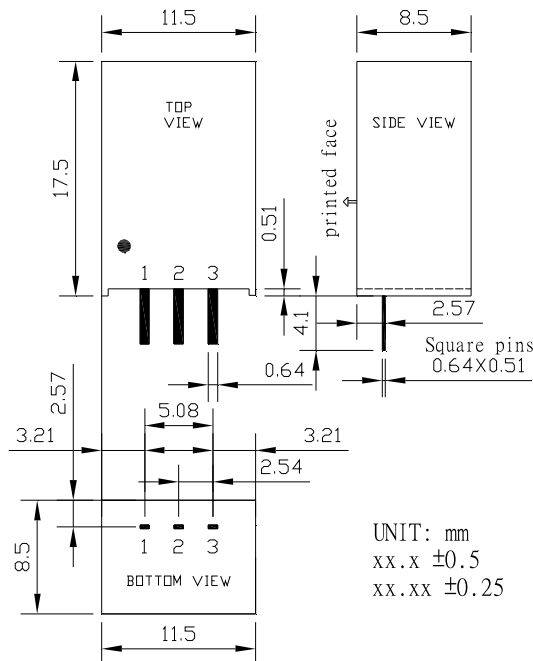

S01D-3A

Non Isolated DC/DC Converter

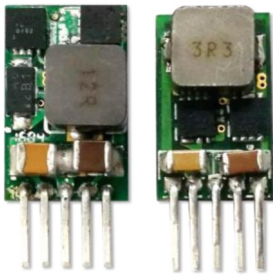

Features

- Open frame packages
- Remote On/Off
- Adjustable output voltages
- Operating Temperature:-40°C TO +85°C
- Efficiency up to 95%, Non isolated, no need for heatsink
- Short circuit protection
- Wide input voltage ranges 4.5~14VDC and 10~30 VDC

Selection Guide

Part Number	Input Voltage (VDC)	Output		Efficiency	
	Nominal (Range)	Output Voltage (VDC)	Output Current (mA)		
S01D-1206-3A	4.5-14	0.59 - 6.0	3000	93	
S01D-2406-3A	10-30	3.0 - 6.0	3000	91	
S01D-2415-3A	10-30	5.0 - 15	3000	95	

MECHANICAL SPECIFICATIONS

S01D-1206-3A

S01D-2406-3A / S01D-2415-3A

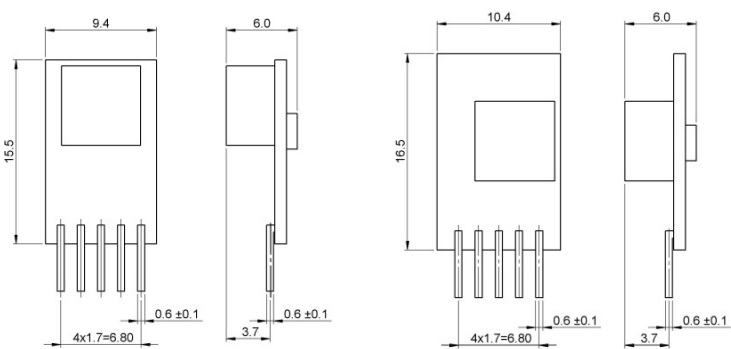

Unit : mm
Tolerance : XX.X±0.5 , XX.XX±0.25

Unit : mm
Tolerance : XX.X±0.5 , XX.XX±0.25

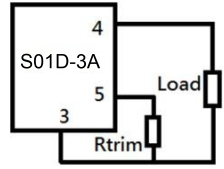

Part Number	R trim [KΩ]
S01D-1206-3A	1.18/(Vo-0.59)
S01D-2406-3A	11.2/(Vo-3)
S01D-2415-3A	8.4/(Vo-5)

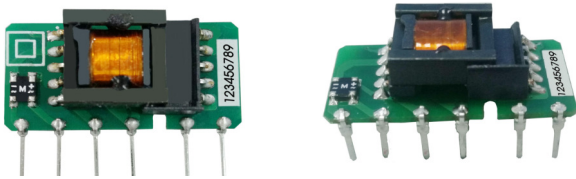

Features

- Ultra wide input voltage range: 85 - 305VAC/70 - 430VDC
- AC and DC dual-use (input from the same terminal)
- Compact size, High power density
- Output short circuit, over-current protection
- IEC60950, UL60950, EN60950 approval

Selection Guide

Certification	Part No.	Output Power	Nominal Output Voltage and Current(Vo/Io)	Efficiency (230VAC, %/Typ.)	Max. Capacitive Load (uF)
UL/CE/CB	SLS01-15B05SS(-F)*	1W	5V/200mA	66	220
	SLS01-15B09SS(-F)		9V/111mA	67	100
	SLS01-15B12SS(-F)		12V/83mA	70	100
	SLS01-15B15SS(-F)		15V/67mA	69	100
	SLS01-15B24SS(-F)		24V/42mA	68	100

Note: *The model of 90 degrees of corner is with -F. For example the SLS01-15B12SS of 90 degrees of corner product is SLS01-15B12SS-F.

MECHANICAL SPECIFICATIONS

SLS01-15BxxSS Dimensions and Recommended Layout

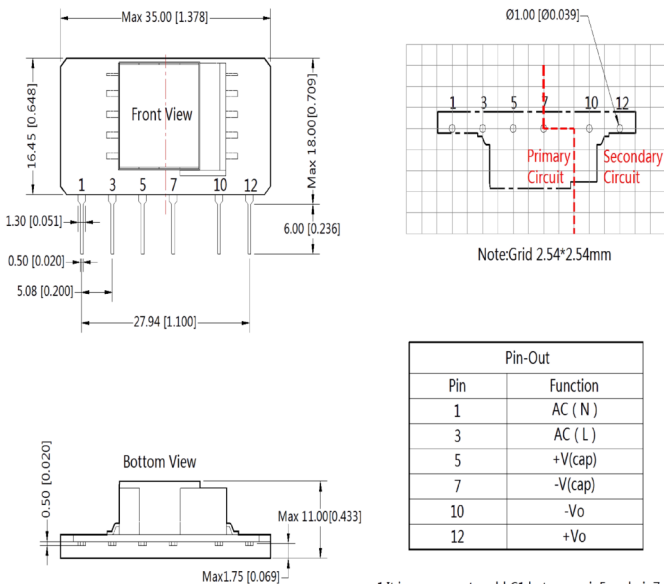

Note:
Unit: mm[inch]
Pin section tolerances: $\pm 0.10[\pm 0.004]$
General tolerances: $\pm 0.50[\pm 0.020]$
The layout of the device is for reference only, please refer to the actual product

1.It is necessary to add C1 between pin5 and pin7 ;
2.It is necessary to add pi-type filter circuit to the output, such as the typical application of Figure 1;
3.It is needed to have distance $\geq 6.4\text{mm}$ for safety between external components in primary circuit and secondary circuit.

SLS01-15BxxSS-F Dimensions and Recommended Layout

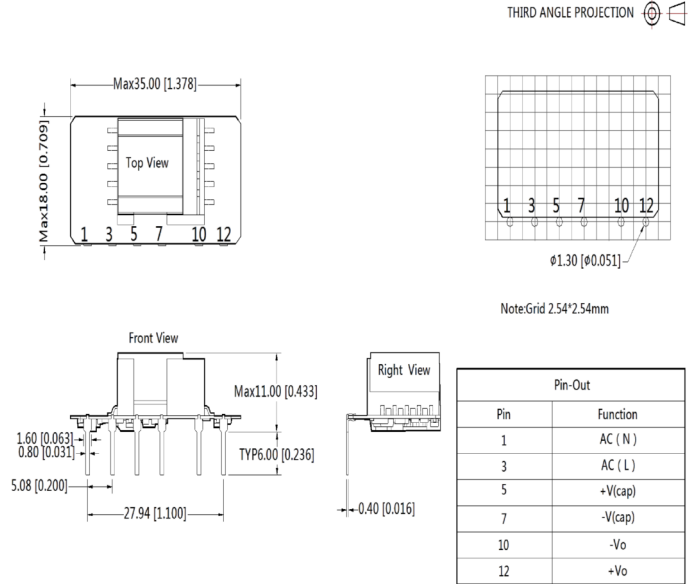

Note:
Unit :mm[inch]
Pin section tolerances: $\pm 0.10[\pm 0.004]$
General tolerances: $\pm 0.50[\pm 0.020]$
The layout of the device is for reference only, please refer to the actual product

1.It is necessary to add C1 between pin5 and pin7 ;
2.It is necessary to add pi-type filter circuit to the output, such as the typical application of Figure 1.

3LS0000015-A0

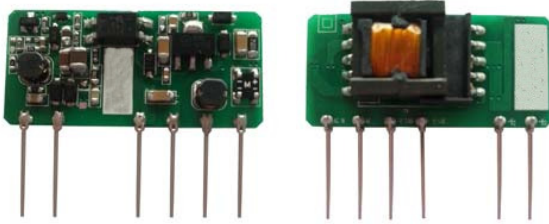

Features

- Wide input voltage range: 85~264VAC/100~400VDC
- Over current protection and short circuit protection
- High efficiency, high safety isolation 3000VAC
- Urtal-slim SIP package
- Industrial grade
- Meet IEC60950, UL60950 and EN60950 standards
- UL60950, EN60950 approval
- 3 years of quality assurance

Selection Guide

Certification	Model	Output Power	Nominal Output Voltage and Current(Vo/Io)	Efficiency (230VAC,%/Typ.)	Max. Capacitive Load (uF)
UL/CE	SLS05-15B03SS	3.3W	3.3V/1A	67	2200
	SLS05-15B05SS	5W	5V/1A	74	1500
	SLS05-15B09SS		9V/0.56A	75	680
	SLS05-15B12SS		12V/0.42A	76	470
	SLS05-15B15SS		15V/0.34A	77	330
	SLS05-15B24SS		24V/0.21A	79	100

MECHANICAL SPECIFICATIONS

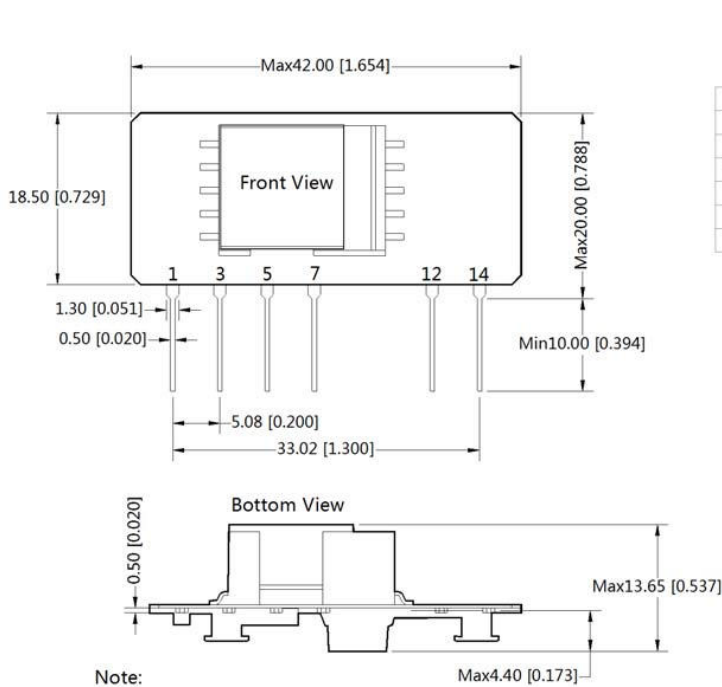

Note:
 Unit :mm[inch]
 Pin section tolerances :±0.10[±0.004]
 General tolerances:±0.50[±0.020]

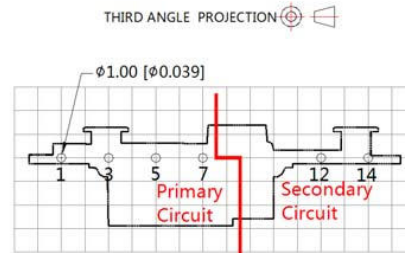

Note:Grid 2.54*2.54mm

Pin-Out	
Pin	Function
1	AC(N)
3	AC(L)
5	+V(cap)
7	-V(cap)
12	-Vo
14	+Vo

- 1.It is necessary to add C1 between pin5 and pin7.
- 2.It is necessary to add circuit to the output,such as the typical application of Figure 1.
- 3..It is needed to have distance ≥6.4mm for safety between external componets in primary circuit and secondary circuit.

3LS0000016-B0



- ### Features
- Universal input voltage range: 85~264VAC/100~370VDC
 - Operating temperature range: -25°C to +70°C
 - Output short circuit, over-current, over-voltage protections
 - UL60950(industrial level), EN60601(Medical safety according to EN 60601 -1 3rd edition) approval
 - Mounting: PCB mounting, Chassis mounting, Din-Rail mounting available

Selection Guide

Certification	Part No.	Output Power	Nominal Output Voltage and Current(Vo/Io)	Efficiency (230VAC, %/Typ.)	Max. Capacitive Load (µF)
UL/CE	SLD10-20B03	10W	3.3V/2000mA	71	15000
	SLD10-20B05		5V/2000mA	76	12000
	SLD10-20B09		9V/1100mA	80	6000
	SLD10-20B12		12V/900mA	81	2000
	SLD10-20B15		15V/700mA	82	1500
	SLD10-20B24		24V/450mA	83	500

MECHANICAL SPECIFICATIONS

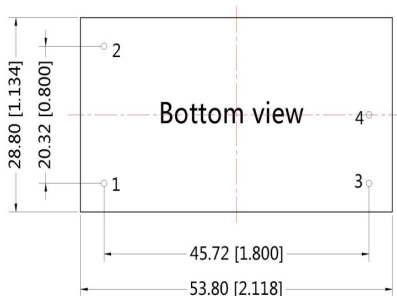
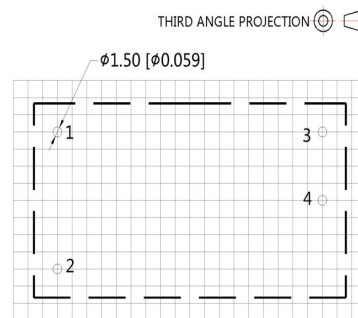
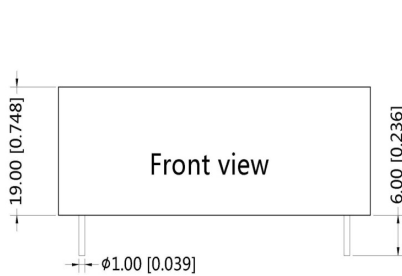

Note : Grid 2.54*2.54mm

Pin-Out	
Pin	Function
1	AC(N)
2	AC(L)
3	+Vo
4	-Vo

Note:
 Unit :mm[inch]
 Pin diameter tolerances :±0.10[±0.004]
 General tolerances:±0.50[±0.020]

1100102702-B0



Features

- Universal Input:85~264VAC/100~370VDC
- AC and DC dual-use(input from the same terminal)
- High efficiency, low power consumption, meet energy star standards
- Low ripple & noise
- Compact size
- Output short circuit, over-current, over-voltage protection
- Mounting: PCB mounting, Chassis mounting, DIN-Rail mounting available
- UL60950, EN60950 approval

Selection Guide

Certification	Model	Output Power	Nominal Output Voltage and Current(Vo/Io)	Efficiency (230VAC./Typ.)	Max. Capacitive Load (μF)
UL/CE	SLD20-10B03	11.88W	3.3V/3600mA	74	10000
	SLD20-10B05	18W	5V/3600mA	78	10000
	SLD20-10B12	20W	12V/1660mA	82	5400
	SLD20-10B15		15V/1330mA	83	2700
	SLD20-10B24		24V/833mA	83	1500

MECHANICAL SPECIFICATIONS

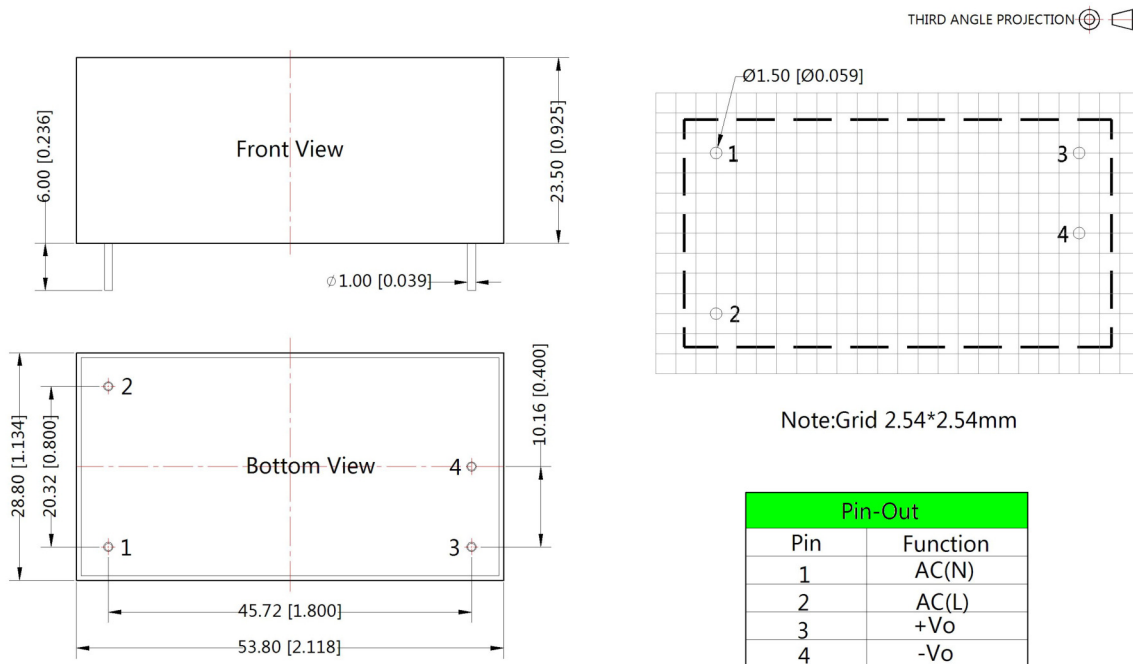

Note:
 Unit :mm[inch]
 Pin diameter tolerances :±0.10[±0.004]
 General tolerances:±0.50[±0.020]



Features

- Wide Input voltage range: 85~264VAC/100~370VDC
- Low standby power consumption: 0.5W, conversion efficiency up to 84%
- Output short circuit, over-current, over-voltage protection
- Meet IEC61000, UL60950 and EN60950 standards
- Mounting: PCB mounting, Chassis mounting, DIN-Rail mounting available

Selection Guide

Certification	Part No.*	Output Power	Nominal Output Voltage and Current		Efficiency (230VAC, %/Typ.)	Max. Capacitive Load(μF)
			(Vo1/Io1)	(Vo2/Io2)		
UL/CE	SLH40-10B03	26.4W	3.3VDC/8000mA	–	78	60000
	SLH40-10B05		5VDC/8000mA	–	82	40000
	SLH40-10B09		9VDC/4444mA	–	84	12000
	SLH40-10B12		12VDC/3333mA	–	84	9000
	SLH40-10B15		15VDC/2666mA	–	84	7000
	SLH40-10B24		24VDC/1667mA	–	84	2000
–	SLH40-10D0512-13	40W	5VDC/5000mA	12VDC/1250mA	82	10000/470
	SLH40-10D0524-06		5VDC/5000mA	24VDC/625mA	82	10000/400
	SLH40-10A05		+5VDC/4000mA	-5VDC/4000mA	82	±12000
	SLH40-10A12		+12VDC/1666mA	-12VDC/1666mA	84	±4400
	SLH40-10A15		+15VDC/1333mA	-15VDC/1333mA	84	±1000

Note:*product model with a suffix of "A5" means chassis mounting and that with a suffix of "A6" indicates DIN-Rail mounting (e.g. SLH40-10B05A5 means chassis mounting; SLH40-10B05A6 means DIN-Rail mounting).

MECHANICAL SPECIFICATIONS

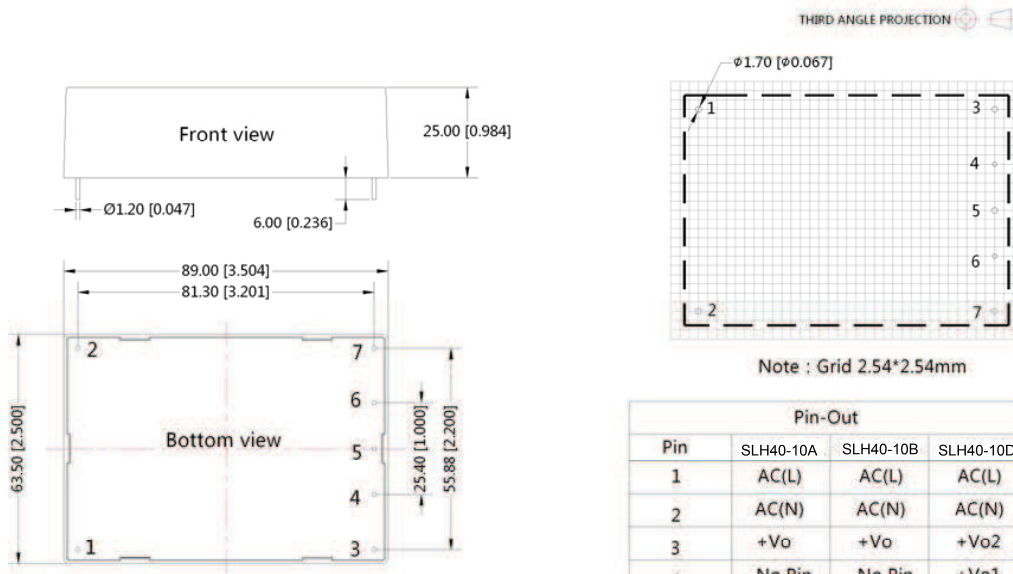

Note:
 Unit :mm[inch]
 Pin diameter tolerances :±0.10[±0.004]
 General tolerances:±0.50[±0.020]

Pin-Out			
Pin	SLH40-10A	SLH40-10B	SLH40-10D
1	AC(L)	AC(L)	AC(L)
2	AC(N)	AC(N)	AC(N)
3	+Vo	+Vo	+Vo2
4	No Pin	No Pin	+Vo1
5	COM	-Vo	-Vo2
6	No Pin	No Pin	-Vo1
7	-Vo	Trim	No Pin



Features

- Wide input voltage range: 90 - 264VAC/122 - 370VDC; 55 - 264VAC/77 - 370VDC(LH60-20Bxx-DT Series)
- Low standby power consumption: 0.5W
- Conversion efficiency up to 86%
- High isolation voltage up to 4K VAC
- Output short circuit, over-current, over-voltage protection
- IEC60950, UL60950, EN60950 approval
- Mounting: PCB mounting, Chassis mounting, DIN-Rail mounting available

Selection Guide

Certification	Part No.*	Output Power	Nominal Output Voltage and Current(Vo/Io)	Efficiency (230VAC, %/Typ.)	Max. Capacitive Load (µF)
UL/CE/CB	SLH60-20B05	50W	5V/10A	82	80000
	SLH60-20B05-DT				
	SLH60-20B09	60W	9V/6.6A	84	28000
	SLH60-20B09-DT				
	SLH60-20B12				
	SLH60-20B12-DT				
	SLH60-20B15				
	SLH60-20B24				
	SLH60-20B24-DT				
SLH60-20B48		48V/1.25A	86	1000	

Note: 1.* SLH60-20Bxx series has input under-voltage protection ; SLH60-20Bxx-DT series has no input under-voltage protection.
 2.*Part No. with a suffix of "A5" means chassis mounting and that with a suffix of "A6" means DIN-Rail mounting (e.g. SLH60-20B05A5 means chassis mounting; SLH60-20B05A6 means DIN-Rail mounting).

MECHANICAL SPECIFICATIONS

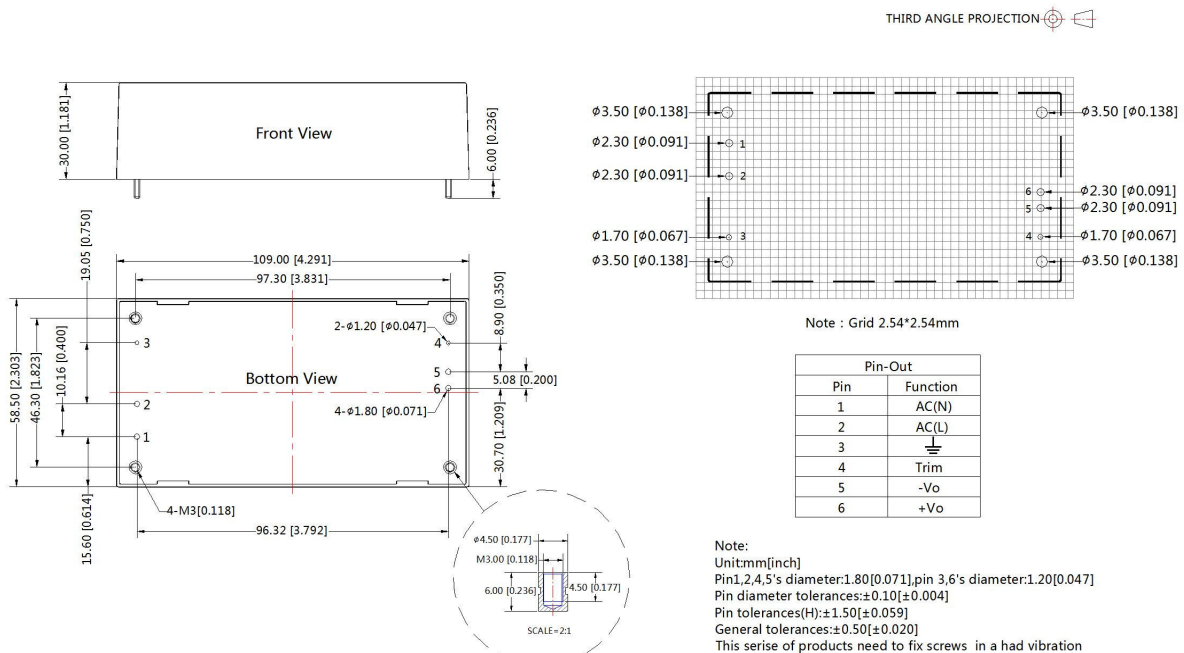



Features

- Universal AC input range
- Short circuit and over current protections
- Board in-line type installation
- High voltage isolation
- Metal Case

Selection Guide

Part No.*	Input Voltage	Output Voltage	Output Current	Output Power
SALR100-12	85-265	12	8.4	100
SALR100-15		15	6.6	100
SALR100-24		24	4.2	100

MECHANICAL SPECIFICATIONS

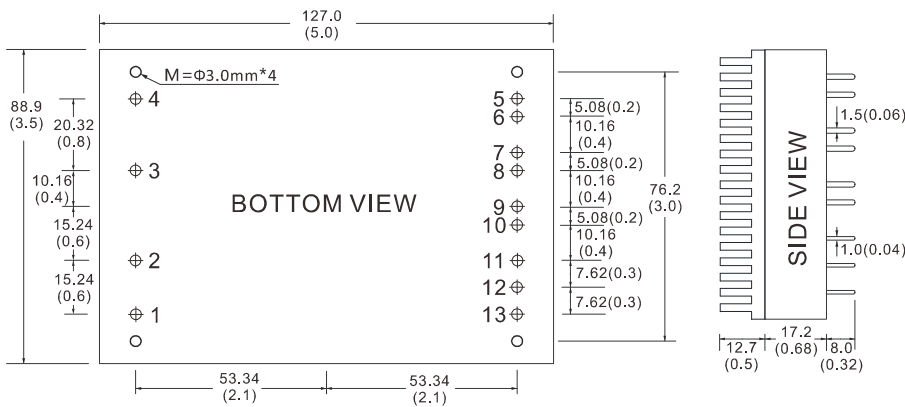

CONNECTION

PIN #	SINGLE
1	NC
2	FG
3	AC(N)
4	AC(L)
5, 6	+Vo
7, 8	No Pin
9, 10	GND
11	+S
12	TRIM
13	-S

Note: Unit is mm(inch);
PIN#1, 2, 11, 12, 13 Φ =1.0mm,
others Φ =1.5mm

LAYOUT

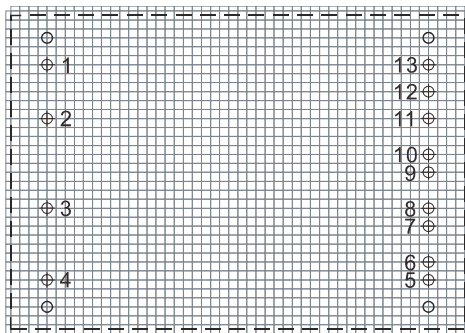

Unit : mm(inch)
PCB vertical view
Grid spacing: 2.54mm(0.1 inch)



Features

- Universal AC input range
- Short circuit and over current protections
- Board in-line type installation
- High voltage isolation
- Metal Case

Selection Guide

Part No.*	Input Voltage	Output Voltage	Output Current	Output Power
SALR150-12	85-265	12	12.5	150
SALR150-15		15	10	150
SALR150-24		24	6.25	150
SALR150-48		48	3.125	150

MECHANICAL SPECIFICATIONS

MECHANICAL

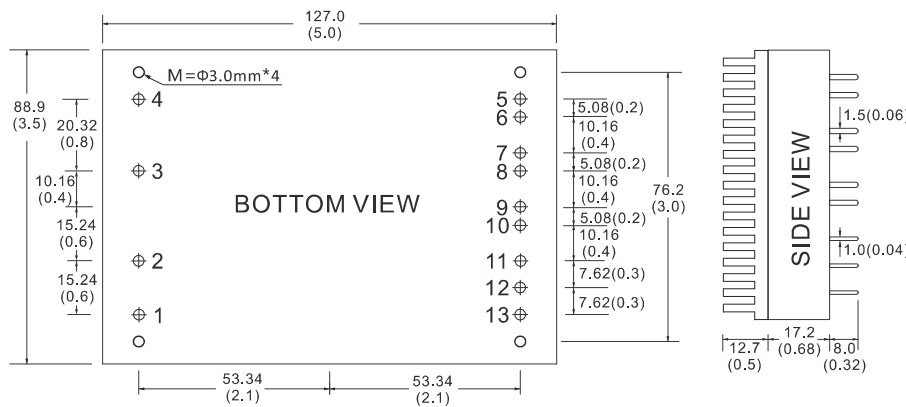

CONNECTION

PIN #	SINGLE
1	NC
2	FG
3	AC(N)
4	AC(L)
5, 6	+Vo
7, 8	No Pin
9, 10	GND
11	+S
12	TRIM
13	-S

Note: Unit is mm(inch);
PIN#1,2,11,12,13Φ=1.0mm,
others Φ=1.5mm

LAYOUT

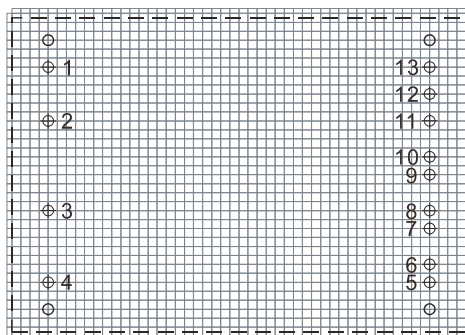

Unit: mm(inch)
PCB vertical view
Grid spacing: 2.54mm(0.1 inch)

General Converter Catalogue

Head Office



SCHMID-MULTITECH GMBH
Weinberbstraße 60b, 93105 Tegernheim
Tel.: +49-9403-9510-0
info@schmid-m.com
www.schmid-m.com



SCHMID-MULTITECH GMBH
Ziemendorf, Dorfstraße 49g
+49-39384-9848-0
39613 Arendsee
info@schmid-m.com
www.schmid-m.com



ATD Elektronik, s.r.o.
Luzenice 10, 344 01 Domazlice
Tel.: +420-379-723-915
info@atd-elektronik.cz
www.atd-elektronik.cz



ABC Elektronik Sp. zo.o.
ul. Kolejowa 10, 38-300 Gorlice
Tel.: +48-18-353-66-65
info@abcpol.pl
www.abcpol.pl



SCHMID-MULTITECH s.r.o.
Podjavorinski 5, 911 05 Trenčín
Tel.: +421-32-7-440-186
mkovacik@smsk.sk
www.schmid-multitech.sk



Angiela Elektronik SRL
Aleea Slanic, nr.1/3
Tel.: +40-264-403-284
info@angiela-elektronik.ro
www.angiela-elektronik.ro



ADMM kft.
Rumi u.284, H-9700 Szombathely
Tel.: +36-94-510-022
mail@admm.hu
www.admm.hu

Also available: Inductors

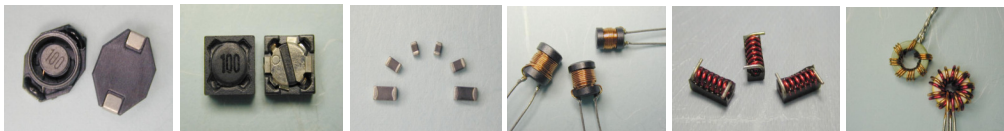

Your reliable partner since 1989.

www.schmid-m.com